

disklavier

■ ■ ■ ■ T V ■ ■ ■ ■

powered by *RemoteLive*[™]

User's Guide

Table of Contents

Introduction	4
Names of Parts and Their Functions	4
Switch Box (Front and Bottom Panel).....	4
Switch Box (Rear Panel)	6
Control Center Unit (for Grand Pianos)	7
Inlet Box (for Upright Pianos).....	8
Monitor Speaker (for compatible Grand Pianos)*	9
Connection Diagram (Basic)	10
Connecting the Disklavier to the Internet	10
Preparation	10
Connection.....	10
Notes on Network Security	11
Watching on Your Tablet — Wired Audio Connection	12
Watching on Your Tablet — Wireless Audio Connection	13
Watching on Your Computer	14
Watching on Your TV	15
Turning on Your Disklavier	16
Registration	17
Preparation	18
Logging into Your Account	18
Activating DisklavierTV	20
Receiving Test	20
Viewing Live Broadcast or On-demand Content	22
Adjustments	24
Adjusting the Main Volume	24
Adjusting the Audio Volume Balance	24

Appendix	25
Windows Audio Considerations	25
Adjusting the Delay	26
Adjusting the Delay of the Piano Playback and Audio	26
Adjusting the Delay of the Piano Playback	27
Adjusting the Depth of the Sustain Pedal	28
Checking the Broadcast Information	29
Network Diagnostics	30
Checking the Error History	32
Troubleshooting	33

Information

- The illustrations as shown in this manual are for instructional purposes only, and may appear somewhat different from those on your instrument.
- Windows is a registered trademark of Microsoft® Corporation in the United States and other countries.
- Android and Google Play are trademarks of Google LLC.
- Mac is trademark of Apple Inc., registered in the U.S. and other countries.
- IOS is a trademark or registered trademark of Cisco in the U.S. and other countries and is used under license.
- The Bluetooth® word mark and logos are registered trademarks owned by Bluetooth SIG, Inc. and any use of such marks by Yamaha Corporation is under license.
- The company names and product names in this manual are the trademarks or registered trademarks of their respective companies.

Introduction

Names of Parts and Their Functions

■ Switch Box (Front and Bottom Panel)

Front panel

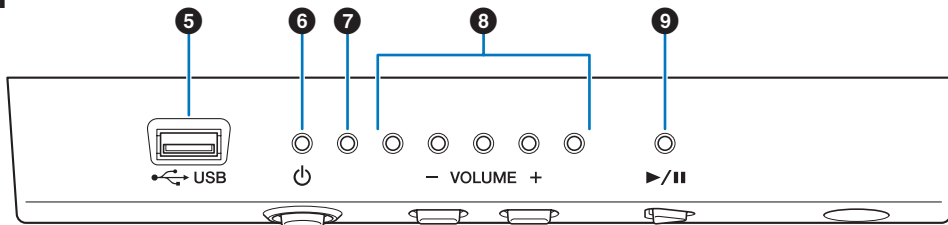

Bottom panel

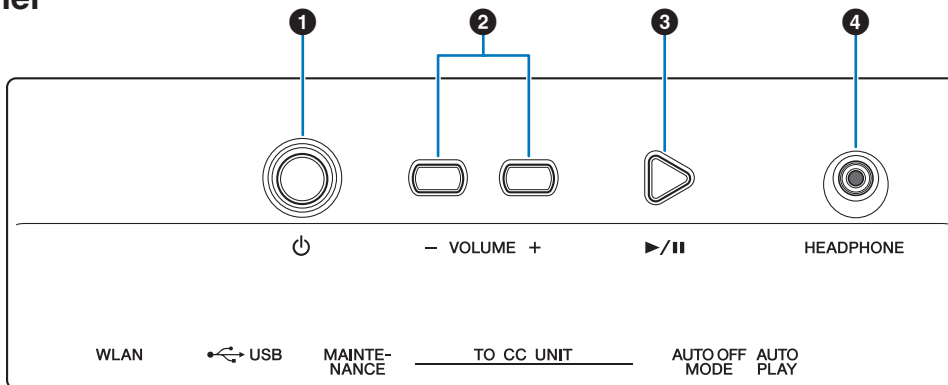

① POWER button

For turning the Disklavier on or off.

② VOLUME +/- buttons

For adjusting the volume.

③ PLAY/PAUSE button

For starting and pauses playback.

- Playback starts from the last loaded song before turning the power off.
- If the last song cannot be loaded, playback starts from the first song of the internal demo songs.

④ HEADPHONE jack

Used to connect the headphones. Connecting headphones mutes the sound from the monitor speakers.

Caution:

- To prevent damage to your hearing, refrain from raising the volume to excessive levels, and do not use the headphones for extended periods of time.
- Do not pull the headphone cord or apply excessive force on the plug. This can damage the headphone and lead to sound output malfunction.

Note:

The keying sound of the keyboard remains even when the headphones are connected.

5 USB port

Used to connect the USB flash memory.

Note:

The unit cannot detect the USB flash memory if two or more memory devices are connected at the same time.

6 POWER  indicator

Shows the power status.

Condition	Status
Lit	The power is turned on.
Dim lit	The power is turned off (standby).
Flashing	The unit is shutting down.
Slow flashing	The unit is starting up.

7 Error indicator

Flashes when some error has occurred.

8 VOLUME indicators

These display the volume level (10 steps). Each indicator shows the volume in 2 steps with brightness.

9 PLAY/PAUSE indicator

Shows the playback status.

Condition	Status
Lit	The song is being played back.
Turning off	The song playback is paused or stopped.

■ Switch Box (Rear Panel)

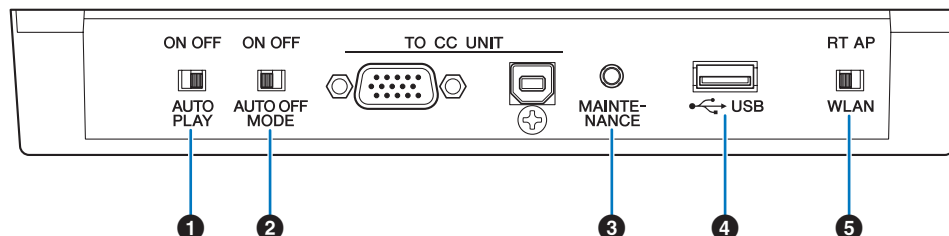

❶ AUTO PLAY switch

For activating or deactivating the auto play function. If you leave the switch set to “ON,” playback automatically starts when the power is turned on.

❷ AUTO OFF MODE switch

For activating or deactivating the auto power-off function. Set this switch to ON to turn the power off automatically if you do not use the Disklavier for the time specified with the ENSPIRE Controller app.

Note:

When set to ON, the Disklavier automatically turns off under the following conditions (for the specified time)

- No operation has been performed on the switch box.
- No operation has been performed on the ENSPIRE Controller app.
- The keyboard has not been played.
- The Disklavier has not received MIDI data.

❸ MAINTENANCE button

For service personnel only. Do not touch this button.

❹ USB port

Used to connect the USB wireless LAN adaptor (UD-WL01).

Note:

The unit cannot detect the USB flash memory if two or more memory devices are connected at the same time.

❺ WLAN switch

For setting the method for wireless LAN connection when connecting the USB wireless LAN adaptor to the USB port.

■ Control Center Unit (for Grand Pianos)

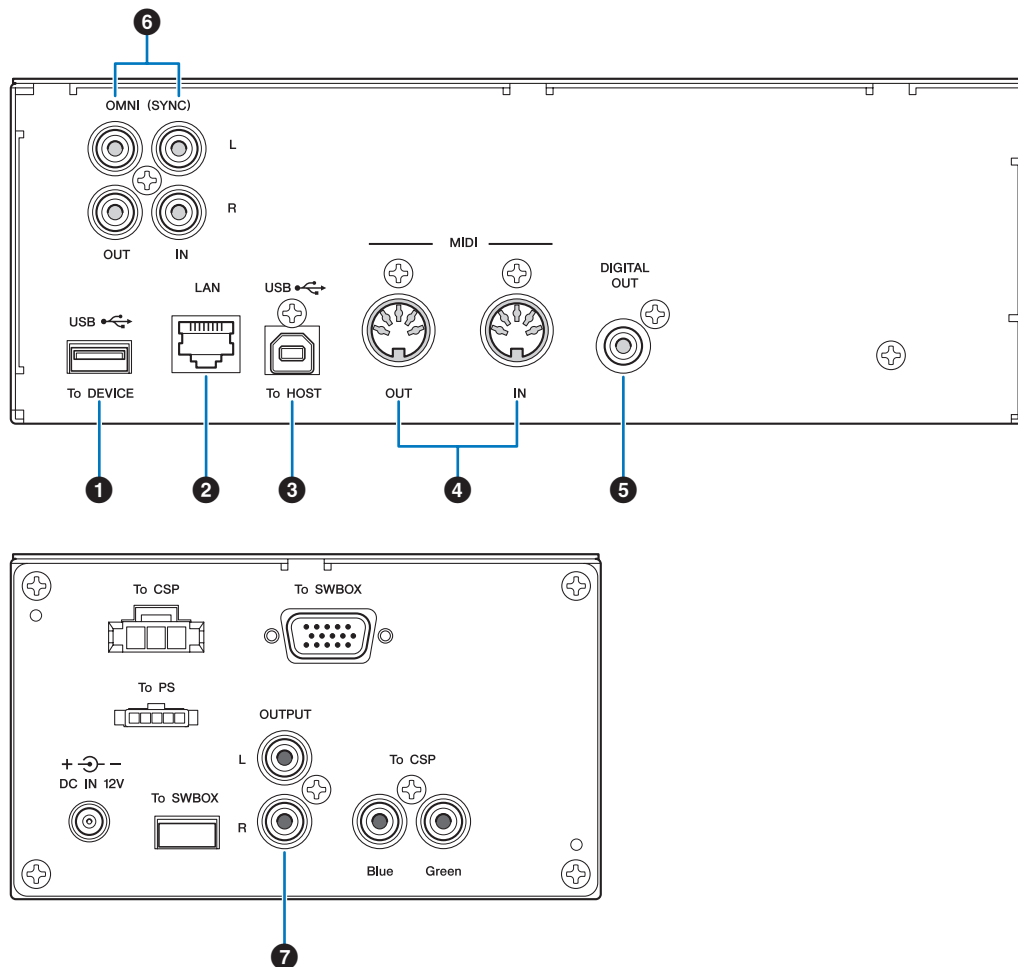

1 USB (To DEVICE) port

Used to connect the USB flash memory.

Note:

The unit cannot detect the USB flash memory if two or more memory devices are connected at the same time.

2 LAN port

Used to connect the router or hub using an Ethernet cable.

3 USB (To HOST) port

Used to connect the computer using a USB cable.

4 MIDI IN/OUT jacks

Used to connect to the MIDI input or output jacks of external MIDI devices using MIDI cables.

5 DIGITAL OUT jack

Used to connect to the digital input jack of an external audio device using a digital coaxial cable.

6 OMNI (SYNC) IN/OUT jacks

Used to connect to the input or output jacks of external audio devices using RCA cables.

7 OUTPUT jacks

Used to connect the monitor speakers.

■ Inlet Box (for Upright Pianos)

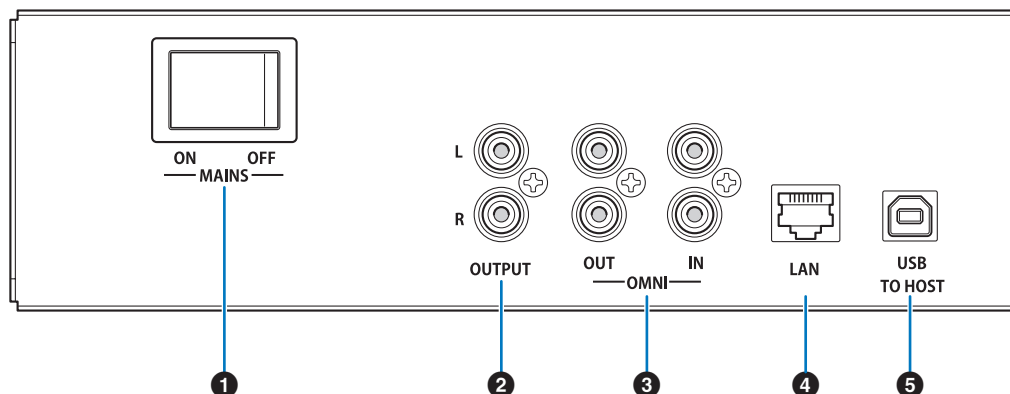

❶ Main switch

For turning the main power on or off.

❷ OUTPUT jacks

Used to connect optional monitor speakers.

❸ OMNI IN/OUT jacks

Used to connect to the input or output jacks of external audio devices using RCA cables.

❹ LAN port

Used to connect the router or hub using an Ethernet cable.

❺ USB (To HOST) port

Used to connect the computer using a USB cable.

■ Monitor Speaker (for compatible Grand Pianos)*

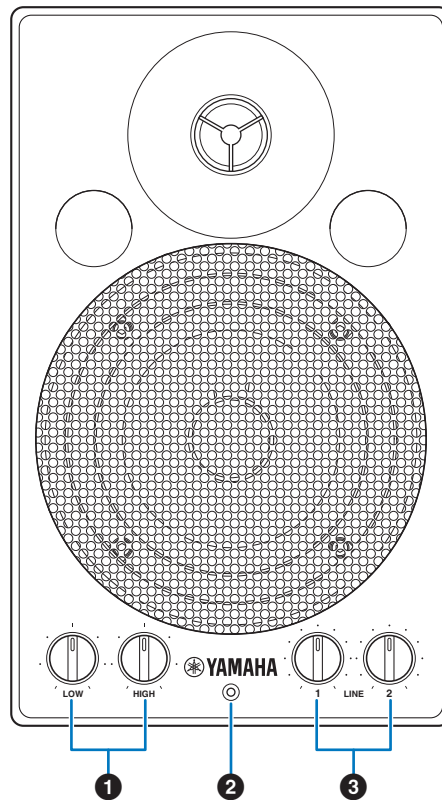

❶ LOW/HIGH volume controls

For adjusting the bass/treble sound volume.

❷ Power indicator

Lights up while the speaker is turned on.

❸ LINE 1/2 volume controls

For adjusting the sound volume of each line input.

Note:

For normal use, turn down the LINE 2 volume completely, and turn up the LINE 1 volume to the three o'clock position.

* Not supplied on some models.

Note:

There may be a notation that says "Only for use with the Disklavier M4 or E3." to the tag attached to the AC power cable; however, it can be used with the Disklavier ENSPIRE series.

Connection Diagram (Basic)

Connecting the Disklavier to the Internet

You can connect the Disklavier to a full-time online Internet connection (ADSL, optical fiber, cable Internet, etc.) via a router or a modem equipped with a router.

■ Preparation

- To use the Internet connection, you will first need to subscribe to an Internet service or provider.
- Use a computer to obtain and configure the device for Internet service. You cannot obtain Internet service or configure router settings on a local area network using the Disklavier itself.
- Before connecting, make sure to turn off (or shut down) the Disklavier.

■ Connection

Wireless Network Connection

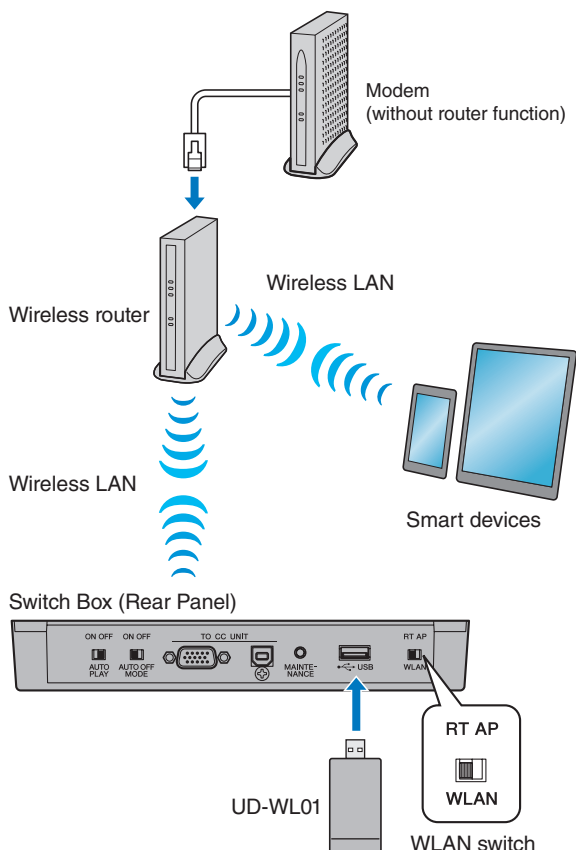

Wired Network Connection

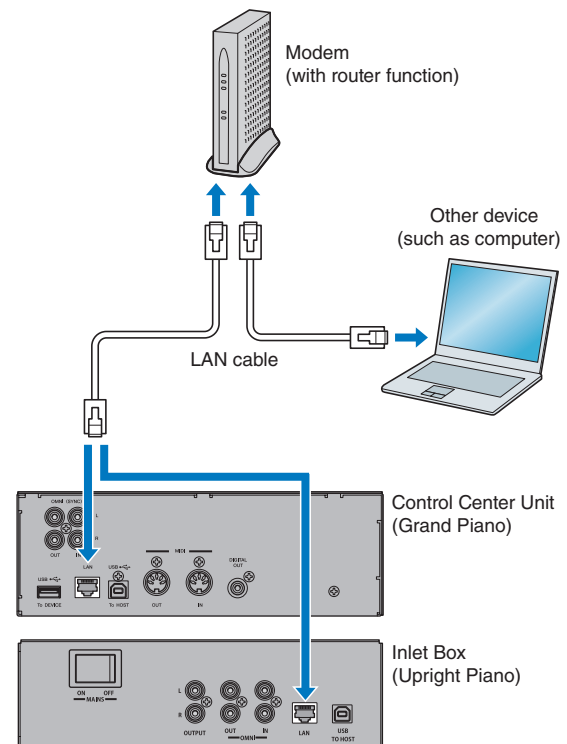

- Note:**
- Depending on the contract with your Internet provider, you may not be able to connect two or more devices (for example, a computer and the Disklavier) to the Internet. Please check your contract or contact your Internet provider for further information.
 - Some types of modems (such as ADSL modems or cable modems) have multiple ports for connecting two or more devices (such as computer, musical instrument, etc.). If your modems have only one port, an optional router or hub is required in order to connect several devices simultaneously.

■ Notes on Network Security

The Disklavier ENSPIRE attempts to achieve a balance between security and usability in its network implementation. However, a determined hacker may be able to defeat these security measures and utilize the network of the purchaser in an unauthorized manner. Since each network is different, only the purchaser can determine whether the security measures discussed here will adequately protect their network.

The purchaser acknowledges that connection to the Internet and use of the Disklavier ENSPIRE Internet features is done at the risk of the purchaser. In no event shall Yamaha, its subsidiaries or Yamaha's and/or its subsidiaries' directors, officers, or employees be responsible for unauthorized access, loss or alteration of the data of the purchaser or be liable for any damage from intrusions.

Watching on Your Tablet — Wired Audio Connection

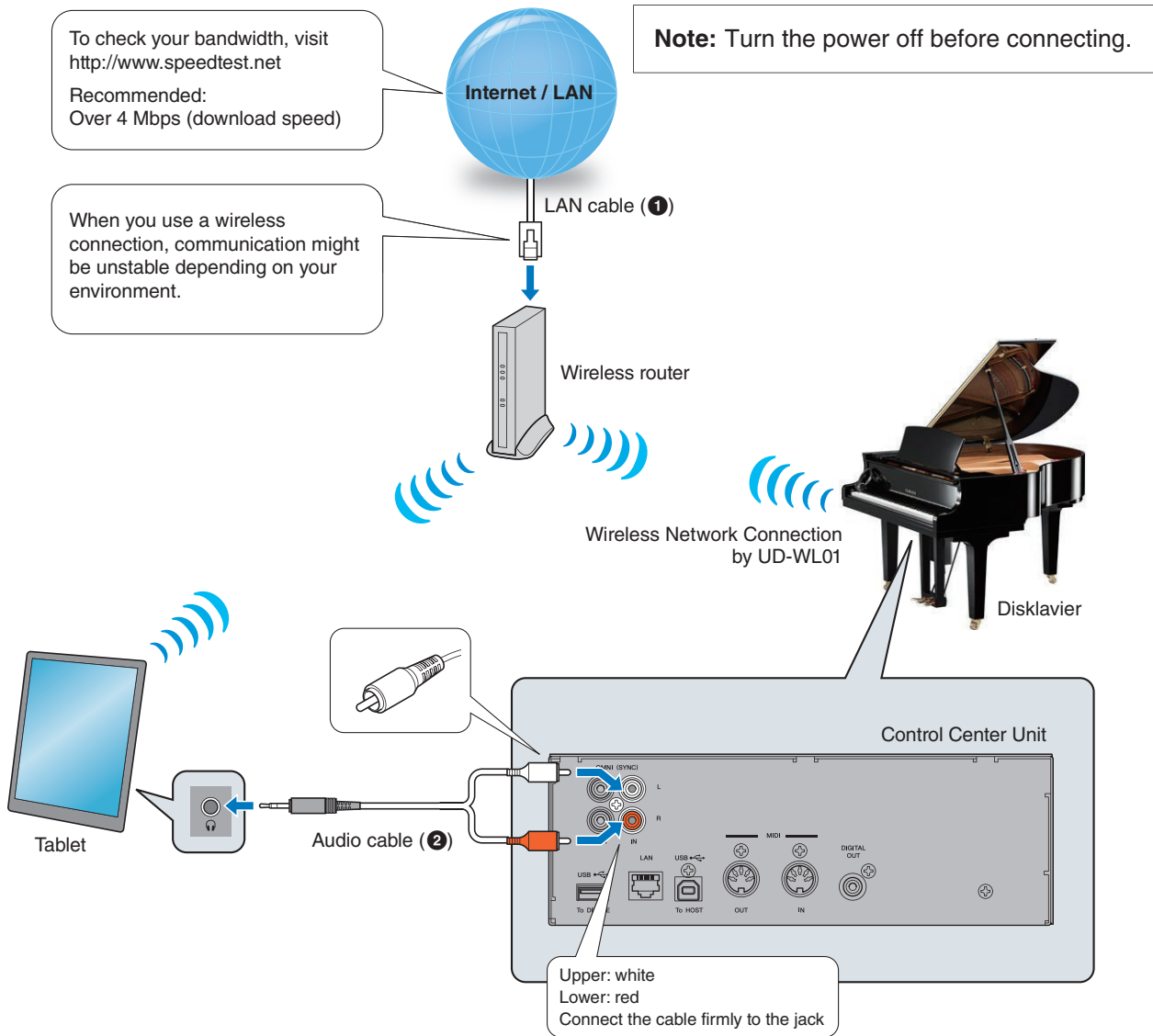

Requirements

(These items are NOT supplied with the Disklavier, with the exception of the USB Wireless LAN Adaptor.)

Equipment	
iOS or Android Tablet	1
Wireless Router	1
USB Wireless LAN Adaptor (UD-WL01)	1

Cables	From	To
LAN cable	Modem	Wireless router ①
Audio cable (stereo mini pin - 2 RCA; male) *1	Tablet	Disklavier ENSPIRE (OMNI IN) ②

*1 DO NOT use cables with impedance changers.

Watching on Your Tablet — Wireless Audio Connection

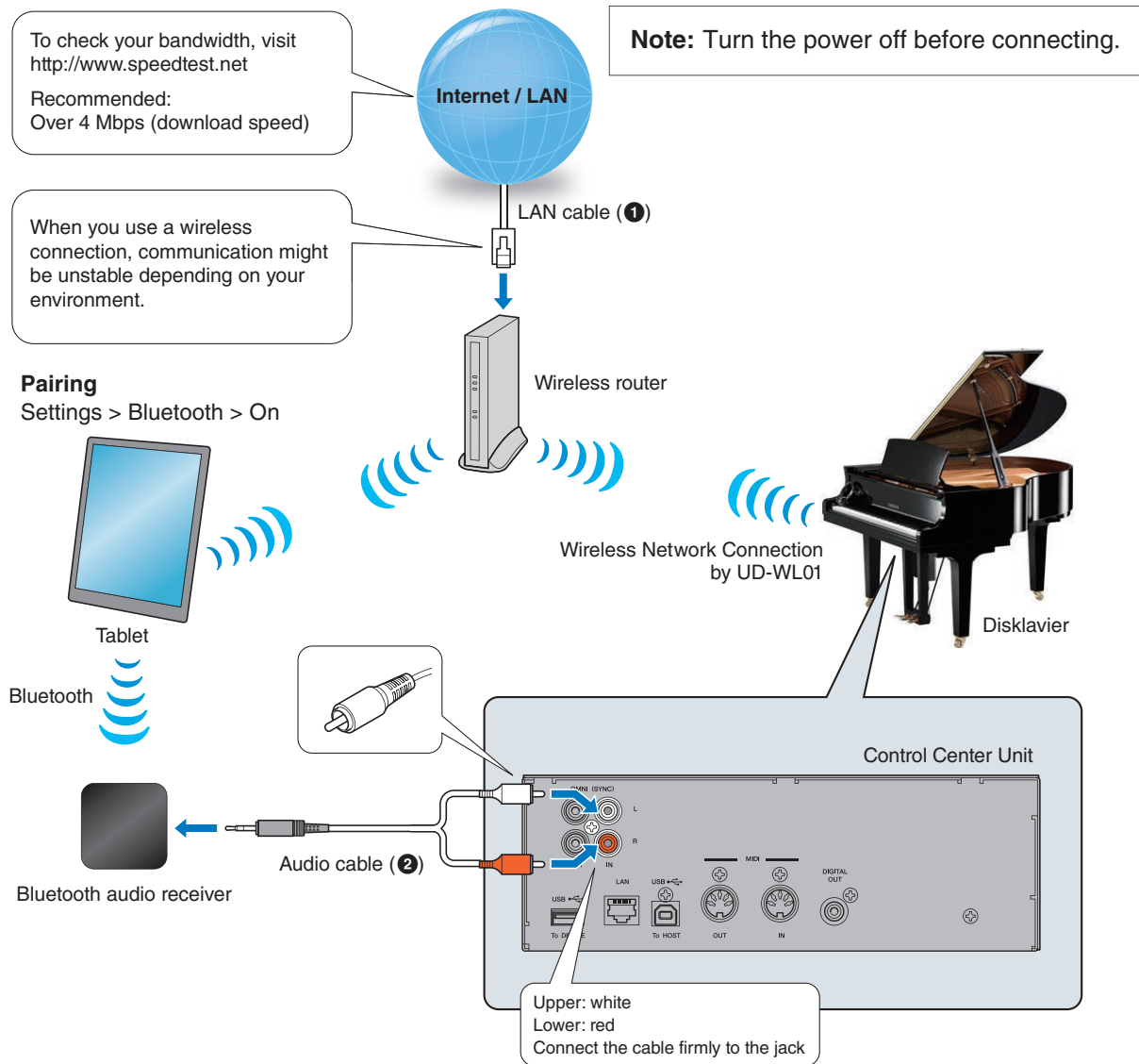

Requirements

(These items are NOT supplied with the Disklavier, with the exception of the USB Wireless LAN Adaptor.)

Equipment	
iOS or Android Tablet	1
Wireless Router	1
USB Wireless LAN Adaptor (UD-WL01)	1
Bluetooth audio receiver *1	1

Cables	From	To
LAN cable	Modem	Wireless router ①
Audio cable (stereo mini pin - 2 RCA; male) *2	Bluetooth audio receiver	Disklavier ENSPIRE (OMNI IN) ②

*1 Bluetooth audio receiver of A2DP profile's aptX, AAC codec support.

The Bluetooth device dictates audio and sync quality, and that the connection distance, stability and quality can vary between different Bluetooth devices.

*2 DO NOT use cables with impedance changers.

Watching on Your Computer

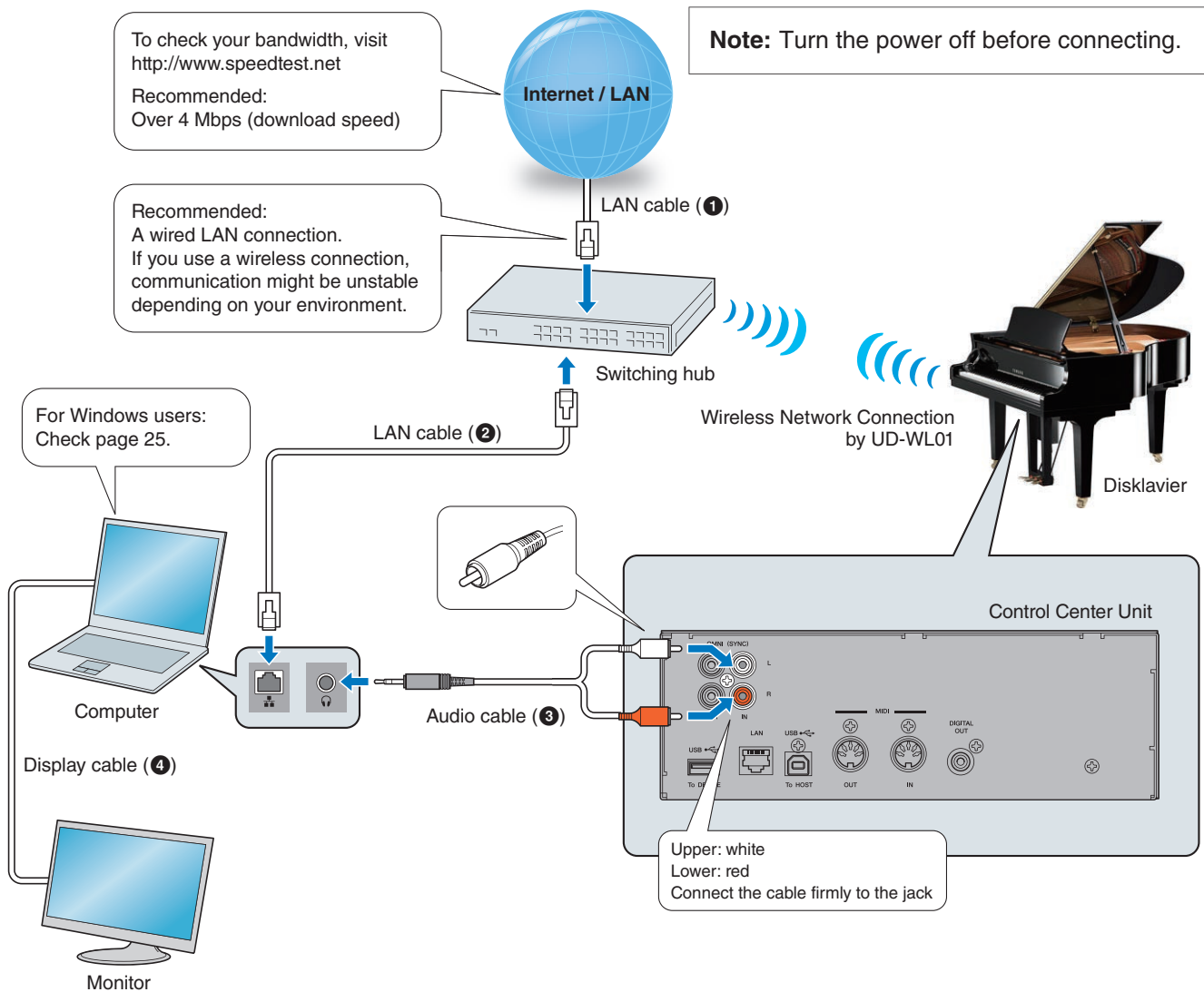

Requirements

(These items are NOT supplied with the Disklavier, with the exception of the USB Wireless LAN Adaptor.)

Equipment	
Computer (Windows or Mac)	1
Switching hub *1	1
USB Wireless LAN Adaptor (UD-WL01)	1

Cables	From	To
LAN cable	1 Modem/router	Switching hub (1)
	1 Switching hub	Computer (2)
Audio cable (stereo mini pin - 2 RCA; male) *2	1 Computer	Disklavier ENSPIRE (OMNI IN) (3)
Display cable	1 Computer	Monitor (4)

*1 You do not need a switching hub if your router has more than 2 empty LAN ports.

*2 DO NOT use cables with impedance changers.

Watching on Your TV

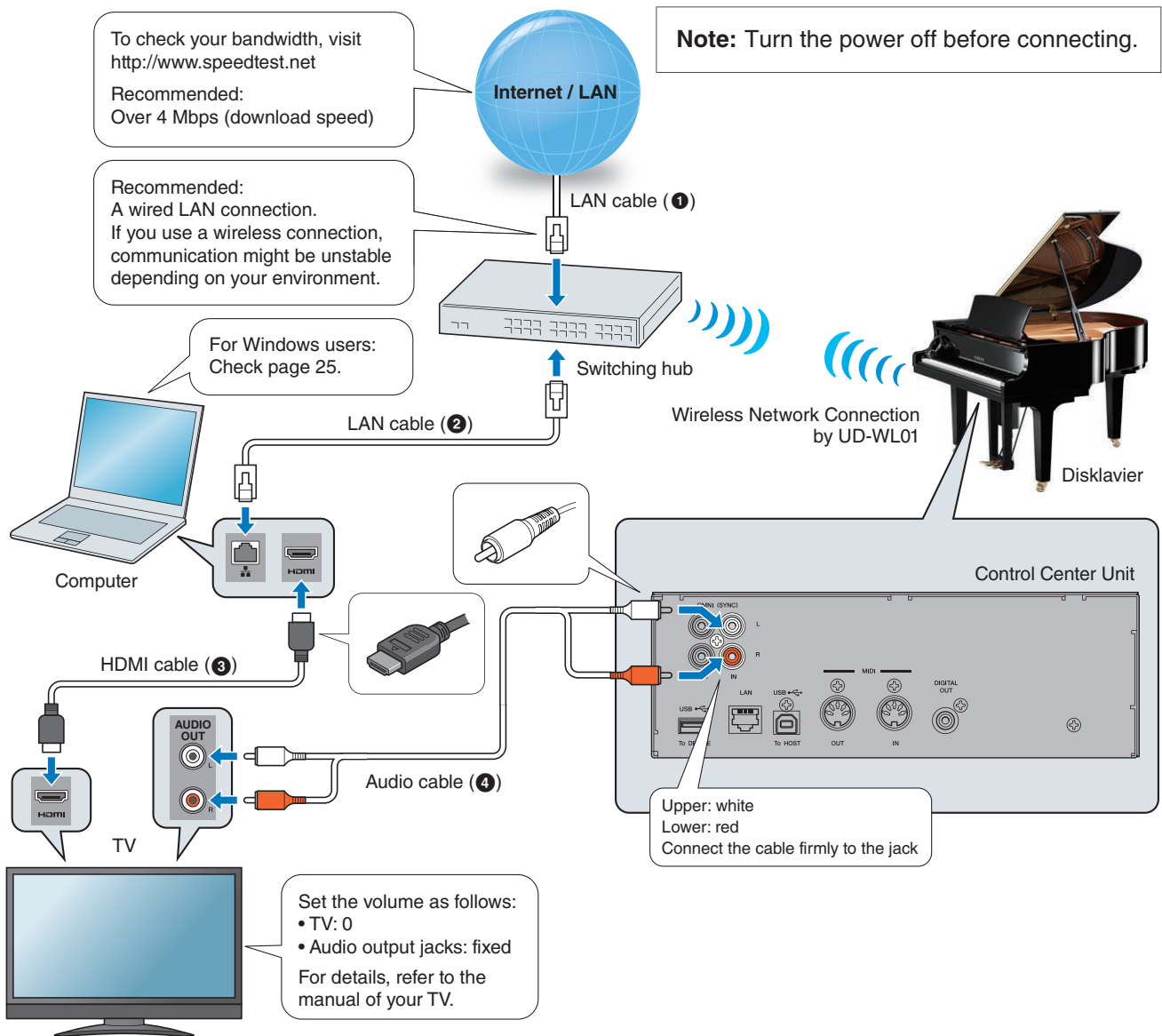

Requirements

(These items are NOT supplied with the Disklavier, with the exception of the USB Wireless LAN Adaptor.)

Equipment	
Computer (Windows or Mac)	1
Switching hub *1	1
TV (with HDMI input and audio output)	1
USB Wireless LAN Adaptor (UD-WL01)	1

Cables	From	To
LAN cable	Modem/router	Switching hub ①
	Switching hub	Computer ②
HDMI cable	Computer	TV ③
Audio cable (2 RCA; male - 2 RCA; male) *2	TV	Disklavier ENSPIRE (OMNI IN) ④

*1 You do not need a switching hub if your router has more than 2 empty LAN ports.

*2 Cable required depends on your TV.

Turning on Your Disklavier

- 1 Make sure that the main switch on the power supply unit/inlet box is turned on.

(Grand piano)

Power supply unit
(located underneath
the piano)

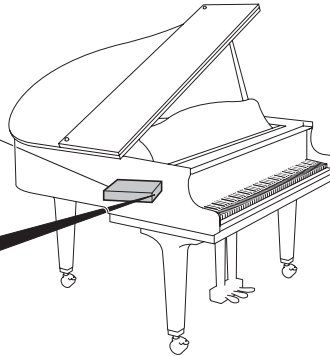
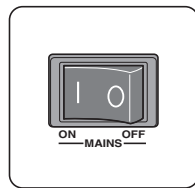

(Upright piano)

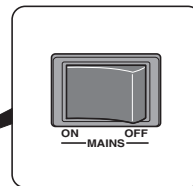
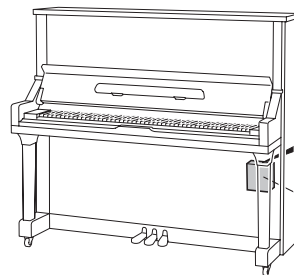

- 2 Press the **POWER** ⏻ button.

The POWER ⏻ indicator flashes slowly (every one second).

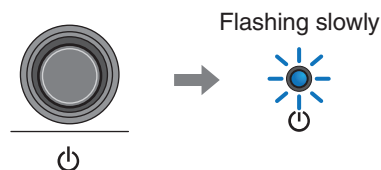

After several seconds, the POWER ⏻ indicator lights up.
Your Disklavier is now ready for use.

Registration

To use the DisklavierTV service, initial registration is required using an Internet-connected computer.

Note: If you are already subscribed to the Piano Radio service, the following procedure is unnecessary.

- 1** Go to <http://www.yamaha.com/DisklavierTV/home.html> and click “Subscribe.”

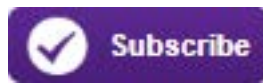

- 2** Select your desired subscription (monthly or annually).
- 3** Click “CHOOSE INSTRUMENT,” then select your instrument.
- 4** Click “SUBSCRIBE,” then confirm your subscription and your auto-renew preference.
- 5** At checkout, you will be asked to create an account to complete the subscription and registration process.

Note: To use the DisklavierTV service, you are required to enter your e-mail address and password with ENSPIRE Controller.

Preparation

Logging into Your Account

- 1 Tap on [Information].**
The [Information] screen appears.

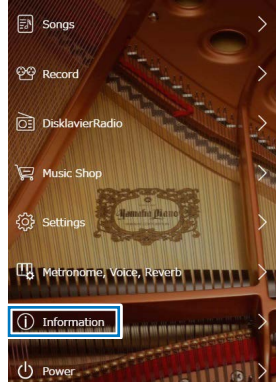

- 2 Tap on [Login].**
The [Login] screen appears.

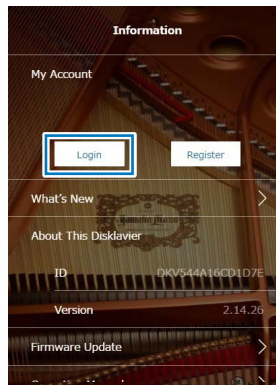

- 3 Tap on [Login].**
The information entry pop-up window appears.

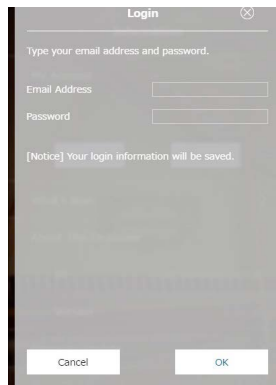

- 4 Enter your e-mail address and password.**

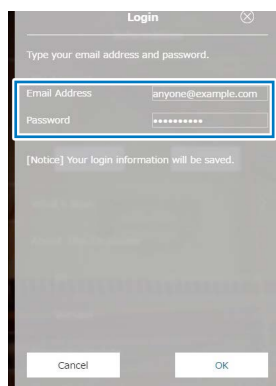

5 Tap on [OK].

If the login is successful, the following pop-up window will appear.

Go to step 6.

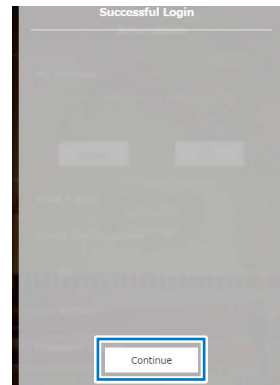

If the login fails, the following pop-up window will appear.

Tap on [Try Again].

Go back to step 4 and make sure that you have entered your e-mail address and password correctly.

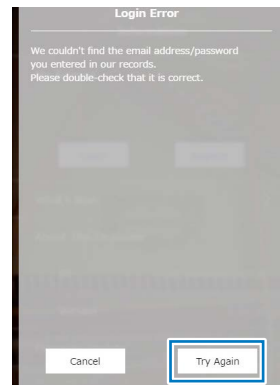
**6** Tap on [Continue].

The [Information] screen appears.

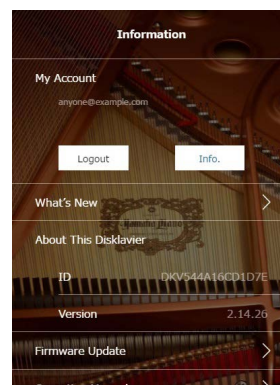
**7** Tap on  (Home) to return to the [Menu] screen.

If you are successfully logged into your account, [DisklavierTV] appears on the [Menu] screen.

You can now enjoy the DisklavierTV service.

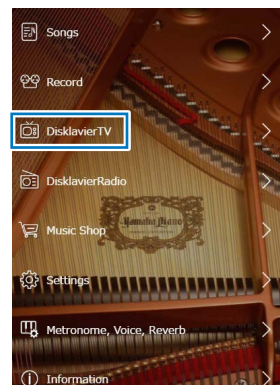

Activating DisklavierTV

Receiving Test

You can verify that you are properly set up to receive a broadcast by viewing a test video that can be found on the website.

- Caution:**
- While you enjoy live broadcast or on-demand content:
 - DO NOT use other applications except your web browser on your computer.
 - DO NOT visit any other websites (other than the URL provided for the broadcast) on your computer.

- Note:**
- Confirm that the volume on your PC is set to maximum.
 - If you are using a PC with Windows, make sure all sound enhancements are disabled (turned off). See “Appendix” on page 25 for additional details.

1 Confirm that all equipment and cables are connected as shown in the “Connection Diagram.”

2 Confirm that your Disklavier can access the Internet.

Tap on [DisklavierTV] in the [Menu] screen.

The [DisklavierTV] screen should appear. If this screen appears, your Internet connection is OK.

You can enjoy the DisklavierTV service. If [DisklavierTV] does not appear, see page 18 for instructions on logging into your account.

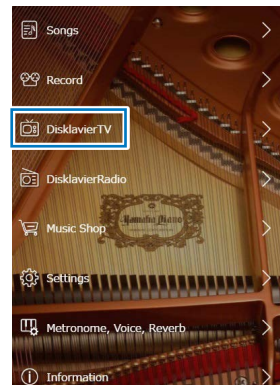

- Note:** If the connection fails, a [Failed to connect the Internet] message appears. If this happens, tap on [OK] to return to the [Main] screen. Turn off the Disklavier and make sure the LAN cable is connected to the Control Center Unit firmly. Then turn on the Disklavier and perform step 1 again. If the connection still fails, see “Setting Up the Disklavier for Internet Connection” in the Advanced Operation Manual and check the setting.

- 3 Tap on [DisklavierTV].**
The [DisklavierTV] screen appears.

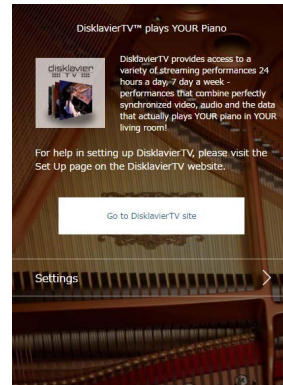

- 4 Using the computer, enter the following URL into your browser:**
4wrd.it/DisklavierTV

- 5 Go to the “Set Up” page, then start playing back the video on the website.**
Your Disklavier starts to receive the data.

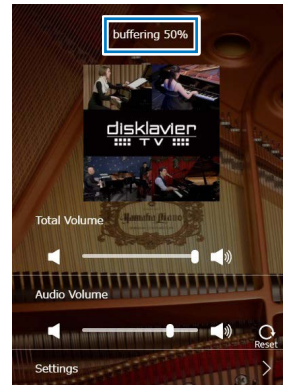

- 6 Confirm that piano playback is synchronized with the video.**

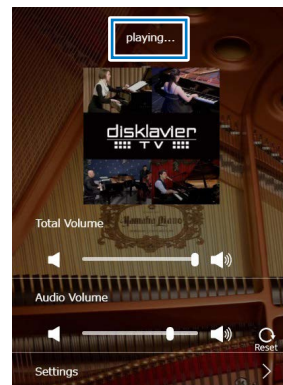

- 7 Confirm that the volume is appropriate.**
See page 24 to adjust the volume.

- 8 Stop playing back the video, and return to the [DisklavierTV] screen.**

Note: Playback of your piano may continue for a while even after you have stopped playing back the video content. This is not a malfunction.

Viewing Live Broadcast or On-demand Content

- Caution:**
- While you enjoy live broadcast or on-demand content:
 - DO NOT use other applications except your web browser on your computer.
 - DO NOT visit any other websites (other than the URL provided for the broadcast) on your computer.

- Note:**
- Confirm that the volume on your PC is set to maximum.
 - If you are using a PC with Windows, make sure all sound enhancements are disabled (turned off). See “Appendix” on page 25 for additional details.

1 Confirm that all equipment and cables are connected as shown in the “Connection Diagram.”

2 Confirm that your Disklavier can access the Internet.

Tap on [DisklavierTV] in the [Menu] screen.

The [DisklavierTV] screen should appear. If this screen appears, your Internet connection is OK.

You can now enjoy the DisklavierTV service.

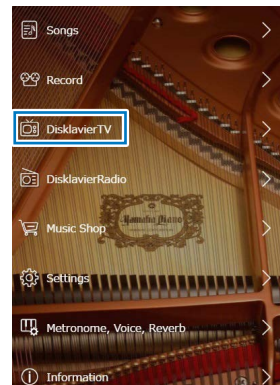

- Note:** If the connection fails, a [Failed to connect the Internet] message appears. If this happens, tap on [OK] to return to the [Main] screen. Turn off the Disklavier and make sure the LAN cable is connected to the Control Center Unit firmly. Then turn on the Disklavier and perform step 1 again. If the connection still fails, see “Setting Up the Disklavier for Internet Connection” in the Advanced Operation Manual and check the setting.

3 Tap on [DisklavierTV].

The [DisklavierTV] screen appears.

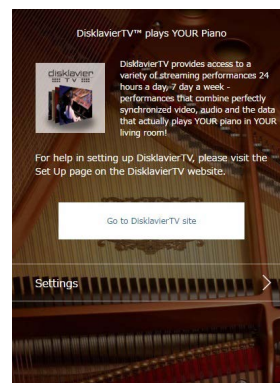

4 Using the computer, enter the following URL into your browser:

4wrd.it/DisklavierTV

5 Start playing back the video on the website.

Your Disklavier starts to receive the data.

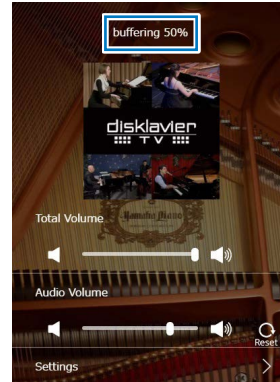

6 Confirm that piano playback is synchronized with the video.

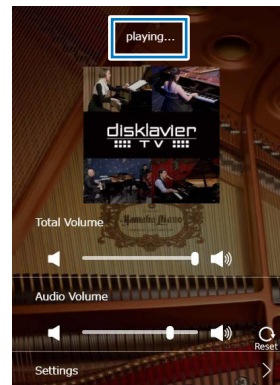

7 Stop playing back the video, and return to the [DisklavierTV] screen.

Note: Playback of your piano may continue for a while even after you have stopped playing back the video content. This is not a malfunction.

Adjustments

Adjusting the Main Volume

You can adjust overall volume.

- 1 Use the slider to adjust the volume.

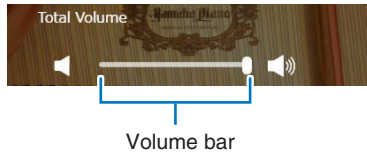

Adjusting the Audio Volume Balance

You can adjust the volume of the audio in balance with the piano sound.

- 1 Tap on [Settings] in the [DisklavierTV] screen.

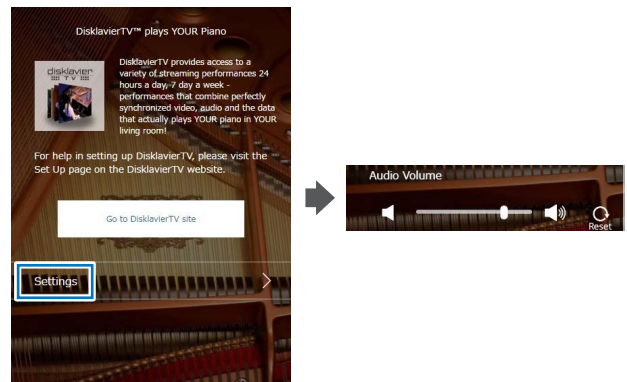

- 2 Tap on any button to adjust the volume of the audio.

🔊 : Audio volume decreases by 1.
🔊 : Audio volume increases by 1.

Audio volume balance can be adjusted over a range of 000 to 127.

- 3 Tap on  (Back) to return to the [DisklavierTV] screen.

Appendix

Windows Audio Considerations

The “sound enhancements” provided by Windows may be desirable for normal audio enjoyment. However, these enhancements cause problems in receiving broadcast or viewing on-demand content, because the *RemoteLive* technology requires discrete separation between the left and right audio channels. For this reason, you **MUST** disable all audio enhancements.

Please check the setting on your own computer. The location of the setting differs depending upon the manufacturer. Here is an example setting.

Start > Desktop > Click the speaker icon > Enhancements > Disable all sound effects > Apply

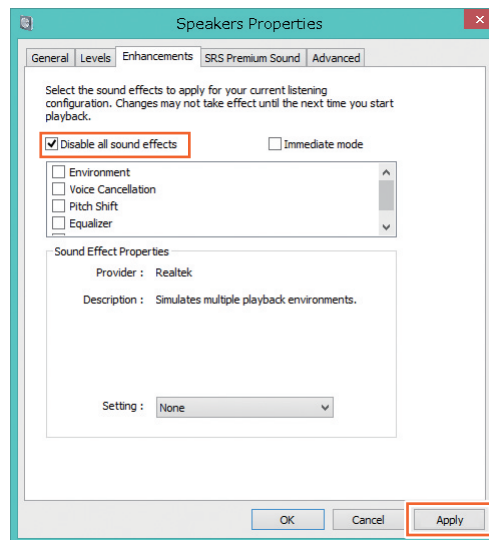
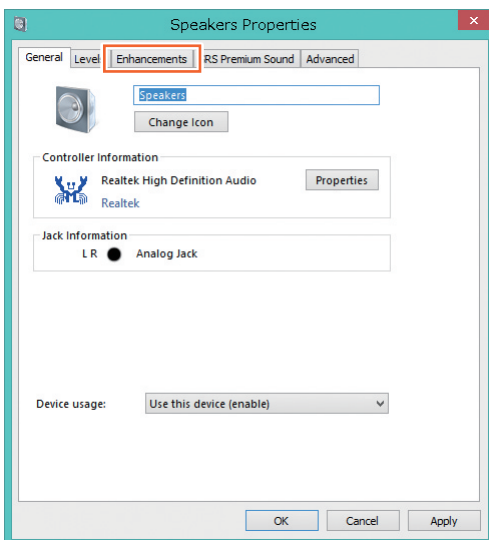
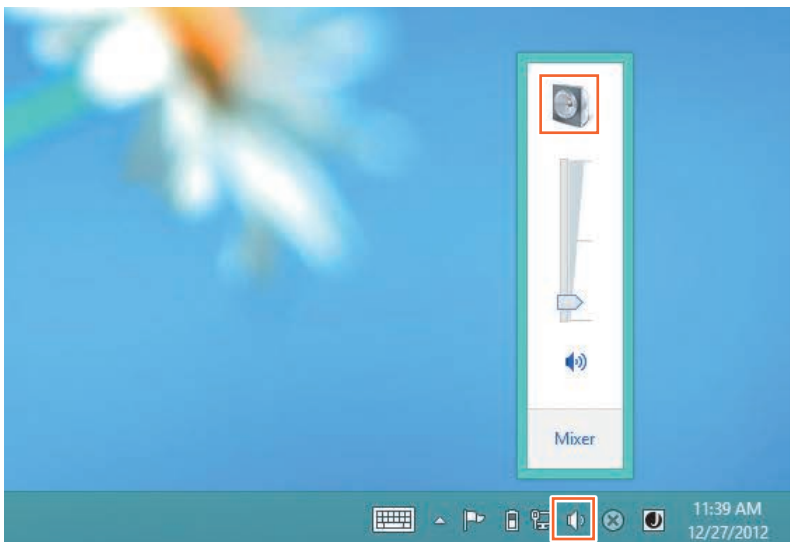

Adjusting the Delay

When there is a disparity between the video or audio and the piano playback, you can adjust the piano playback or audio delay in order to match the video or audio.

■ Adjusting the Delay of the Piano Playback and Audio

You can adjust the delay of the piano playback and audio input through the SYNC IN jacks in order to match the video.

1 Tap on [Settings] in the [DisklavierTV] screen.

The [Settings] function menu screen appears.

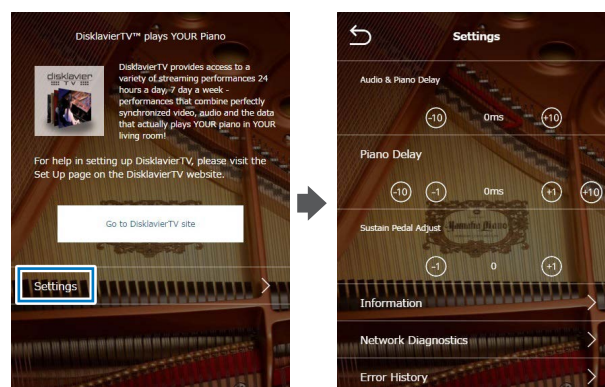

2 Tap on [-10] or [+10] to change the setting.

The delay time can be adjusted in a range of 0 ms to 500 ms (in increments of 10 ms). Increase this value to delay the piano playback and audio input.

3 Tap on (Back) to return to the [DisklavierTV] function menu screen.

■ Adjusting the Delay of the Piano Playback

You can adjust the piano playback delay in order to match the audio from the device connected to the OMNI OUT jacks.

1 Tap on [Settings] in the [DisklavierTV] screen.

The [Settings] function menu screen appears.

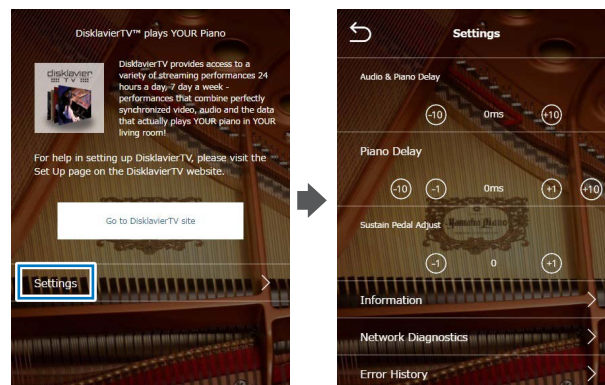

2 Tap on [-10] or [+10] to change the setting.

The delay time can be adjusted in a range of 0 ms to 500 ms (in increments of 1 ms). Increase this value to delay the piano playback.

3 Tap on (Back) to return to the [DisklavierTV] function menu screen.

Adjusting the Depth of the Sustain Pedal

You can adjust the depth of the sustain pedal.

1 Tap on [Settings] in the [DisklavierTV] screen.

The [Settings] function menu screen appears.

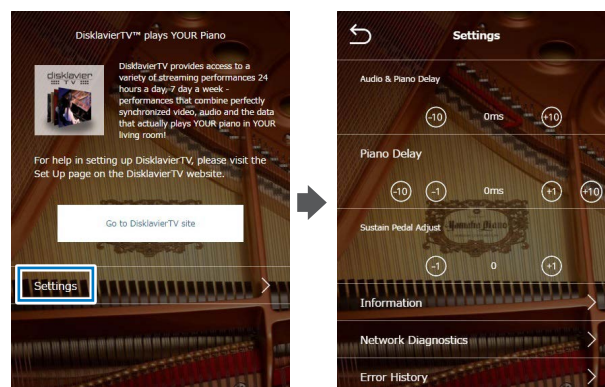

2 Tap on [-1] or [+1] to change the setting while listening to the piano playback.

Increasing this value increases the effect of the sustain pedal, and decreasing this value decreases the effect of the sustain pedal.

The setting range varies depending on the model and its condition.

3 Tap on (Back) to return to the [DisklavierTV] screen.

Checking the Broadcast Information

You can check the information about the broadcast.

1 Tap on [Information] in the [Settings] screen.

The [Information] function menu screen appears.

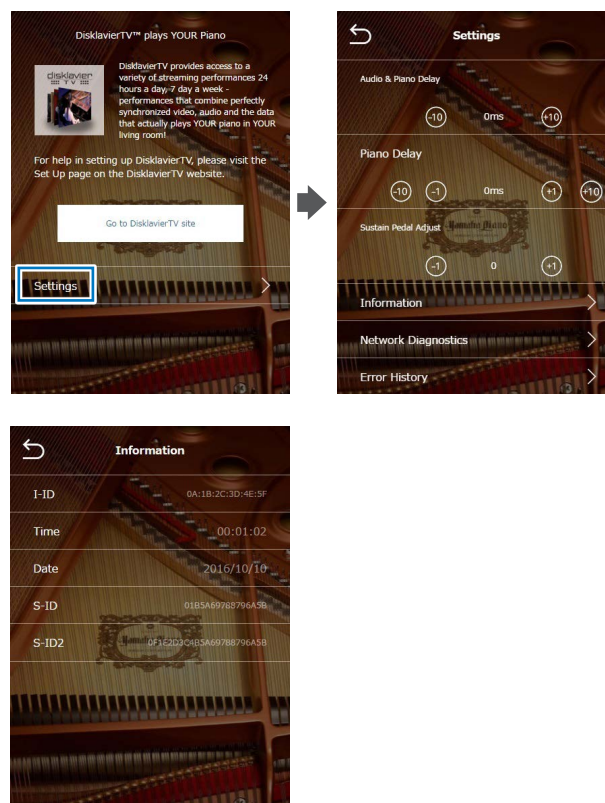

[I-ID]: ID of the broadcast Disklavier

[Time]: Playing time of your Disklavier

[Date]: Date and time when your Disklavier was played back

[S-ID]: ID of the piano performance data

[S-ID2]: ID of the piano performance data

2 Tap on (Back) to return to the [Settings] function menu screen.

Network Diagnostics

In some cases, it may be necessary to perform network diagnostics to determine the cause of problems. In these instances, follow the procedure below:

1 Tap on [Settings] in the [DisklavierTV] screen.

The [Settings] function menu screen appears.

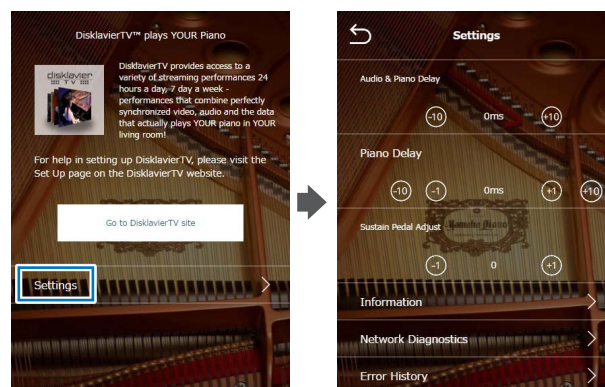

2 Tap on [Network Diagnostics].

The [Network Diagnostics] pop-up window appears and the diagnostics process starts.

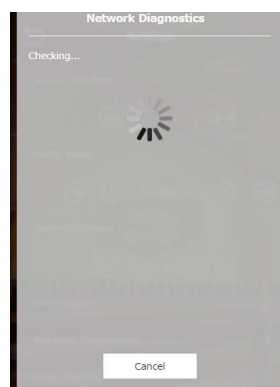

When the diagnostics process is completed, the resulting error number and message is displayed.

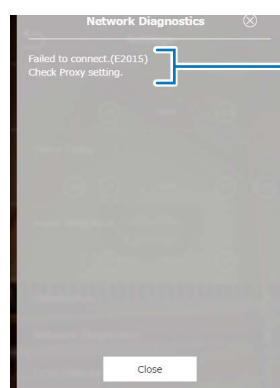

Error number and message

3 Tap on (Back) to return to the [DisklavierTV] function menu screen.

Error Messages

Number	Message	Remedy
0000	Network OK.	No problem.
2012	Failed to connect.(2012) Check Network setting.	Make sure that the IP address of your Disklavier has been set correctly.
2013	Failed to connect.(2013) Check DNS setting.	Make sure that the DNS server address has been set correctly.
2014	Failed to connect.(2014) DNS is not available.	Make sure that the overall network settings (DHCP setting, DNS server address, IP address, subnet mask and gateway server address) on your Disklavier have been set correctly. If the problem persists, please contact your internet service provider.
2015	Failed to connect.(2015) Check Proxy setting.	Make sure that the proxy server has been set correctly.
2010	Failed to connect.(2010) Cannot connect to server.	The <i>RemoteLive</i> server may be temporarily down for maintenance. Please try again later.
2011	Failed to connect.	Check the cable.

Checking the Error History

You can check the error history.

1 Tap on [Error History] in the [Settings] screen.

The [Error History] function menu screen appears.

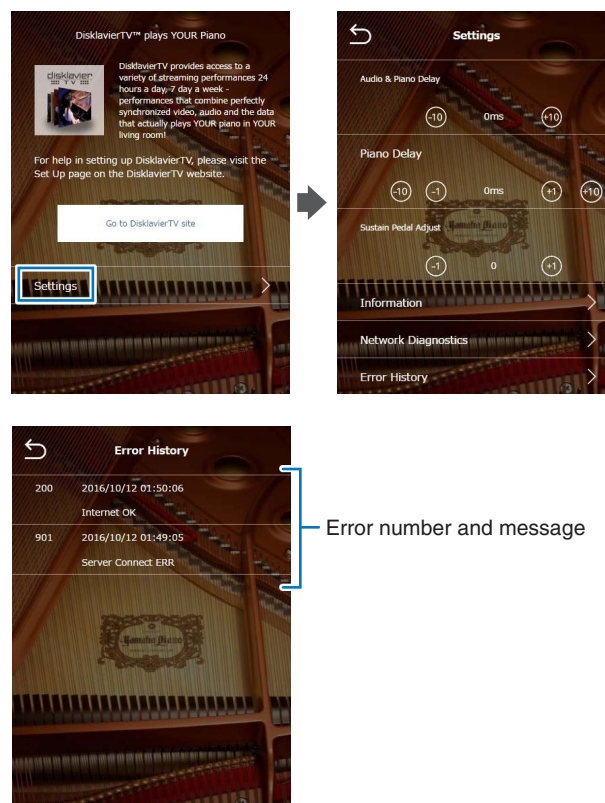

2 Tap on (Back) to return to the [DisklavierTV] function menu screen.

Troubleshooting

Piano

Symptom	Remedy
The Disklavier does not turn on.	Make sure that the AC power cable is securely connected to a suitable AC wall outlet.
Some notes drop out during playback.	Contact your local Yamaha customer service.
No sound is heard from the piano even though piano keys are moving.	Disengage the quiet mode. Tap on [Acoustic] on the Balance screen.
Pedals are not moving.	Disengage the quiet mode. Tap on [Acoustic] on the Balance screen.
The volume of the piano playback is too low.	See page 24 on adjusting main volume.
The piano playback and audio is not synchronized with video streaming.	See page 26 on adjusting the delay.
The piano playback is not synchronized with audio.	See page 27 on adjusting the delay.
Pedal adjustment is inappropriate.	See page 28 on adjusting the pedal.
Piano keys are not moving.	Make sure that the audio volume of computer is adequately turned up. Make sure that the surround system on your computer is TURNED OFF. Audio enhancements prevent DisklavierTV from working properly. Make sure that your computer is suitable for watching DisklavierTV contents. See page 20 to try viewing a test video. Make sure that the audio cable is correctly connected to the audio input jack. Make sure that the audio cable is firmly connected to the audio input jack on your computer. If the symptom persists, connect the headphones to the jack and try listening to audio playback to confirm whether the jack is defective. Replace the audio cable. Reverse the left and right connection, and then check whether or not the piano keys are moving. Make sure that you are using the audio cable without impedance changer. In case you are using a USB audio interface, make sure that the USB audio driver is correctly installed on your computer. In case you are using a USB audio interface, make sure that USB audio is selected in the audio device setting on your computer. In case you are using a USB audio interface, make sure that the USB audio output volume is adequately turned up. In case you are using a USB audio interface, make sure that only the input from your computer is connected to the USB audio interface. If the input from any other device is connected, disconnect it or set its volume to 0. In case you are using a USB audio interface, make sure that the input and output on the USB audio interface are correctly connected.

Controller

Symptom	Remedy
"DisklavierTV" does not appear in the Menu.	Make sure that your Disklavier firmware is the latest version on the [Information] screen.
	See page 17 and register as a Yamaha Online Member by creating your account on Yamaha MusicSoft.
	See page 18 and properly log into your account (enter the e-mail and password registered on Yamaha MusicSoft).
	Make sure that your credit card information includes a United States mailing address.

Switching Hub

Symptom	Remedy
Failed to open the website on your browser.	Make sure that the switching hub and router are connected with the Ethernet cable.
	Make sure that the switching hub and computer are connected with the Ethernet cable.

Computer

Symptom	Remedy
Video streaming does not start.	Make sure that the operating system on your computer is suitable for watching DisklavierTV contents.
	Disable the firewall function on your computer. Be sure to enable it after you confirm that the symptom is improved.
Video streaming is not smooth.	Make sure that your computer is suitable for watching DisklavierTV contents. See page 20 to try viewing a test video.
	Disable the antivirus software on your computer. Be sure to enable it after you confirm that the symptom is improved.
	Disable the firewall function on your computer. Be sure to enable it after you confirm that the symptom is improved.
	Make sure that no other software except the web browser is working.
Failed to open the website on your browser.	Make sure that the router is turned on.
	Make sure that the Ethernet cable is securely connected to the router.
	Make sure that the router and switching hub are connected with the Ethernet cable.
Failed to open the website on your browser.	Make sure that the router setting is appropriate.
	Contact your ISP and confirm the contract for speed.
Video streaming is not smooth.	Check your bandwidth using a speed test site (e.g., http://www.speedtest.net). We recommend over 4.0 Mbps for download speed. If the symptom persists, contact your ISP and confirm the contract for speed.
Piano playback is not stable due to unstable video streaming.	Check your bandwidth using a speed test site (e.g., http://www.speedtest.net). We recommend over 4.0 Mbps for download speed. If the symptom persists, contact your ISP and confirm the contract for speed.

Speakers

Symptom	Remedy
The audio from the speakers is not in sync with the video (audio is delayed).	See page 27 on adjusting the delay. Check the audio delay specifications of the speakers.
The audio from the speakers is not in sync with the piano playback (audio is delayed).	See page 27 on adjusting the delay. Check the audio delay specifications of the speakers.
No sound is heard from the speakers.	Make sure that the speakers are turned on. Make sure that the audio cable is firmly connected to the speaker. Make sure that the audio cable is not disconnected.
The speaker volume is too low.	Make sure that the speaker volume is adequately turned up. Make sure that the volume of the desired input is turned up. Make sure that you are using the audio cable without impedance changer.
No video sound is heard from the speakers connected to the OUTPUT jacks.	See page 24 on adjusting audio balance. See page 24 on adjusting main volume.
The left channel sound is heard more than once or seems to have an echo.	It is possible that you have the DisklavierTV website opened more than once. Make sure that ONLY the DisklavierTV website is opened. Reboot your computer.
No sound is heard from the speakers.	Make sure that the audio volume of computer is adequately turned up. Make sure that the audio cable is correctly connected to the audio input jack. Make sure that the USB audio driver is correctly installed on your computer. Make sure that USB audio is selected in the audio device setting on your computer. Make sure that the USB audio output volume is adequately turned up.
The speaker volume is too low.	Make sure that the audio volume of computer is adequately turned up. Make sure that you are using the audio cable without impedance changer. Replace the audio cable. In case you are using a USB audio interface, make sure that the USB audio output volume is adequately turned up.
Hissing sound is coming from the speakers.	Make sure that the surround system on your computer is TURNED OFF. Audio enhancements prevent DisklavierTV from working properly. Reverse the left and right connection, and then check the sound is appropriately output from the speakers. Replace the audio cable. Make sure that you are using a stereo audio cable.

Symptom	Remedy
Speaker output is unstable.	<p>Make sure that the audio cable is firmly connected to the audio input jack on your computer. If the symptom persists, connect the headphones to the jack and try listening to audio playback to confirm whether the jack is defective or not.</p> <hr/> <p>Replace the audio cable.</p>
Audio input through the USB audio input jack is being mixed into the speaker sound (in case you are using a USB audio interface).	<p>Make sure that only the input from your computer is connected to the USB audio interface. If the input from any other device is connected, disconnect it or set its volume to 0.</p>
No sound is output from the USB audio interface.	<p>Make sure that the output on the USB audio interface is correctly connected to your Disklavier.</p>

External Monitor

Symptom	Remedy
The video image on the external monitor is not in sync with the audio from the speakers (video is delayed).	<p>See page 26 on adjusting the delay.</p>
The video image on the external monitor is not in sync with the piano playback (video is delayed).	<p>See page 26 on adjusting the delay.</p>
No video image is displayed on the external monitor.	<p>Make sure that you have selected the desired input.</p> <hr/> <p>Make sure that the display cable is connected.</p>
Hissing sound is coming from the external monitor.	<p>Make sure that the audio volume of the external monitor is set to 0.</p>
The external monitor sleeps during playback.	<p>Disable the power-saving setting on the external monitor.</p>

Contact Us

Online: 4wrd.it/D-TVsupport



YAMAHA CORPORATION

10-1 Nakazawa-cho, Naka-ku, Hamamatsu, 430-8650 Japan
Manual Development Group

© 2016 Yamaha Corporation
Published 06/2018 MW-C0