



MIXING CONSOLE

# AG03 Technical Specifications

## General Specifications

0 dBu = 0.775 Vrms, Output impedance of signal generator (Rs) = 150 Ω

All level controls are nominal if not specified.

<b>Frequency Response</b>	<b>Input (MIC) to MONITOR OUT via USB IN/OUT</b>	+0.5 dB/-1.5 dB (20 Hz to 48 kHz @ Fs = 192 kHz), refer to the nominal output level @ 1 kHz, GAIN knob: Min, TO PC: DRY CH1-2G
<b>Total Harmonic Distortion *1 (THD+N)</b>	<b>Input to MONITOR OUT</b>	0.05% @ 0 dBu (20 Hz to 20 kHz), GAIN knob: Min 0.01% @ +4 dBu (1 kHz), GAIN knob: Min
<b>Hum&amp;Noise *2 (20 Hz to 20 kHz)</b>	<b>Equivalent Input Noise</b>	-128 dBu (Mono Input Channel, Rs: 150 Ω, GAIN knob: Max)
	<b>Residual Output Noise</b>	-103 dBu (MONITOR OUT, MONITOR knob: Min)
<b>Crosstalk (1 kHz) *3</b>		-80 dB
<b>Input Channels</b>		Mono (MIC/LINE): 1 including HEADSET MIC (Plug-in Power) (CH1 MIC and HEADSET MIC cannot be used simultaneously.), Stereo (LINE) / Mono (GUITAR) :1, USB IN:1, AUX IN:1
<b>Output Channels</b>		MONITOR OUT: 2, PHONES: 2 including HEADSET PHONES (PHONES and HEADSET PHONES cannot be used simultaneously.)
<b>Bus</b>		Stereo: 1
<b>Input Channel Function (CH1)</b>	<b>PAD</b>	26 dB
	<b>DSP</b>	COMP/EQ, EFFECT (SPX Reverb)
	<b>PEAK LED</b>	LED turns on when the signal reaches 3 dB below clipping level.
<b>Level Meter</b>	<b>USB Output Level</b>	2x2 point LED meter [PEAK, SIG]
<b>USB Audio</b>	<b>2 IN / 2 OUT</b>	USB Audio Class 2.0 compliant, Sampling Frequency: Max 192 kHz, Bit Depth: 24-bit
<b>Phantom Power Voltage</b>		+48 V
<b>FOOT SW</b>		EFFECT Mute on/off
<b>Power Requirements</b>		DC 5 V, 500 mA
<b>Power Consumption</b>		Max. 2.5 W
<b>Dimensions (WxHxD)</b>		129 mm x 63 mm x 202 mm
<b>Net Weight</b>		0.8 kg
<b>Included Accessory</b>		USB Cable (1.5 m), CUBASE AI DOWNLOAD INFORMATION, Owner's Manual, Technical Specifications (this leaflet)
<b>Optional Accessory</b>		Foot Switch: FC5, Mic Stand Adaptor: BMS-10A
<b>Operating Temperature</b>		0 to +40°C

\*1 THD+N is measured with 22 kHz LPF.

\*2 Noise is measured with A-weighting filter.

\*3 Crosstalk is measured with 1 kHz band pass filter.

The contents of this manual apply to the latest specifications as of the printing date. To obtain the latest manual, access the Yamaha website then download the manual file.

## Analog Input Characteristics

0 dBu = 0.775 Vrms

Input Jack	PAD 26 dB	GAIN Trim/SW Position	Actual Load Impedance	For Use with Nominal	Input Level			Connector
					Sensitivity *1	Nominal	Max. Before Clip	
MIC/LINE 1 HEADSET MIC	OFF	10	3 kΩ 1.5 kΩ*4	50–600 Ω Mics/Lines	-72 dBu (0.195 mV)	-60 dBu (0.775 mV)	-50 dBu (2.451 mV)	Combo jack *2 (Balanced) 3.5 mm Phone jack for HEADSET MIC (Plug-in Power/ Unbalanced)
		0			-26 dBu (38.84 mV)	-14 dBu (154.6 mV)	-4 dBu (489.0 mV)	
	ON	10			-46 dBu (3.884 mV)	-34 dBu (15.46 mV)	-24 dBu (48.90 mV)	
		0			0 dBu (775.0 mV)	+12 dBu (3.085 V)	+22 dBu (9.757 V)	
GUITAR 2G	-	HIGH	1 MΩ	-	-32 dBu (19.5 mV)	-20 dBu (77.5 mV)	-10 dBu (245.1 mV)	Phone jack *3 (Unbalanced)
		LOW			-12 dBu (194.7 mV)	0 dBu (775.0 mV)	+10 dBu (2.451 V)	
LINE 2/3	-	HIGH	10 kΩ	600 Ω Lines	-20 dBu (77.5 mV)	-8 dBu (308.5 mV)	+2 dBu (973.7 mV)	Phone jack *3 (Unbalanced)
		LOW			-10 dBu (245.1 mV)	+2 dBu (975.7 mV)	+12 dBu (3.085 V)	
AUX	-	-	10 kΩ	600 Ω Lines	-14 dBu (154.6 mV)	-8 dBu (308.5 mV)	+2 dBu (975.7 mV)	Stereo mini jack

\*1 Sensitivity is the lowest level that will produce an output of +0 dBu (0.775 V) or the nominal output level when the unit is set to maximum gain. (All level controls are at their maximum position.)

\*2 1&Sleeve = GND, 2&Tip = HOT, 3&Ring = COLD

\*3 Tip = Signal, Sleeve = GND

\*4 For CH1, HEADSET MIC

## Analog Output Characteristics

0 dBu = 0.775 Vrms

Output Terminal	Actual Source Impedance	For Use with Nominal	Output Level		Connector
			Nominal	Max. Before Clip	
MONITOR OUT [L, R]	150 Ω	10 kΩ Lines	0 dBu (0.775 V)	+10 dBu (2.451 V)	Phone jack *5 (Impedance Balanced) RCA pin (Unbalanced)
PHONES	120 Ω	40 Ω Phones	1.5 mW + 1.5 mW	6 mW + 6 mW	Stereo phone jack Stereo mini jack

\*5 Tip = HOT, Ring = COLD, Sleeve = GND

## Digital Input / Output Characteristics

Terminal	Format	Data Length	Sampling Frequency	Connector
USB	USB Audio Class 2.0/ Yamaha Steinberg USB Driver	24-bit	44.1 kHz, 48 kHz, 88.2 kHz, 96 kHz, 176.4 kHz, 192 kHz	USB Standard-B

# Block and Level Diagrams

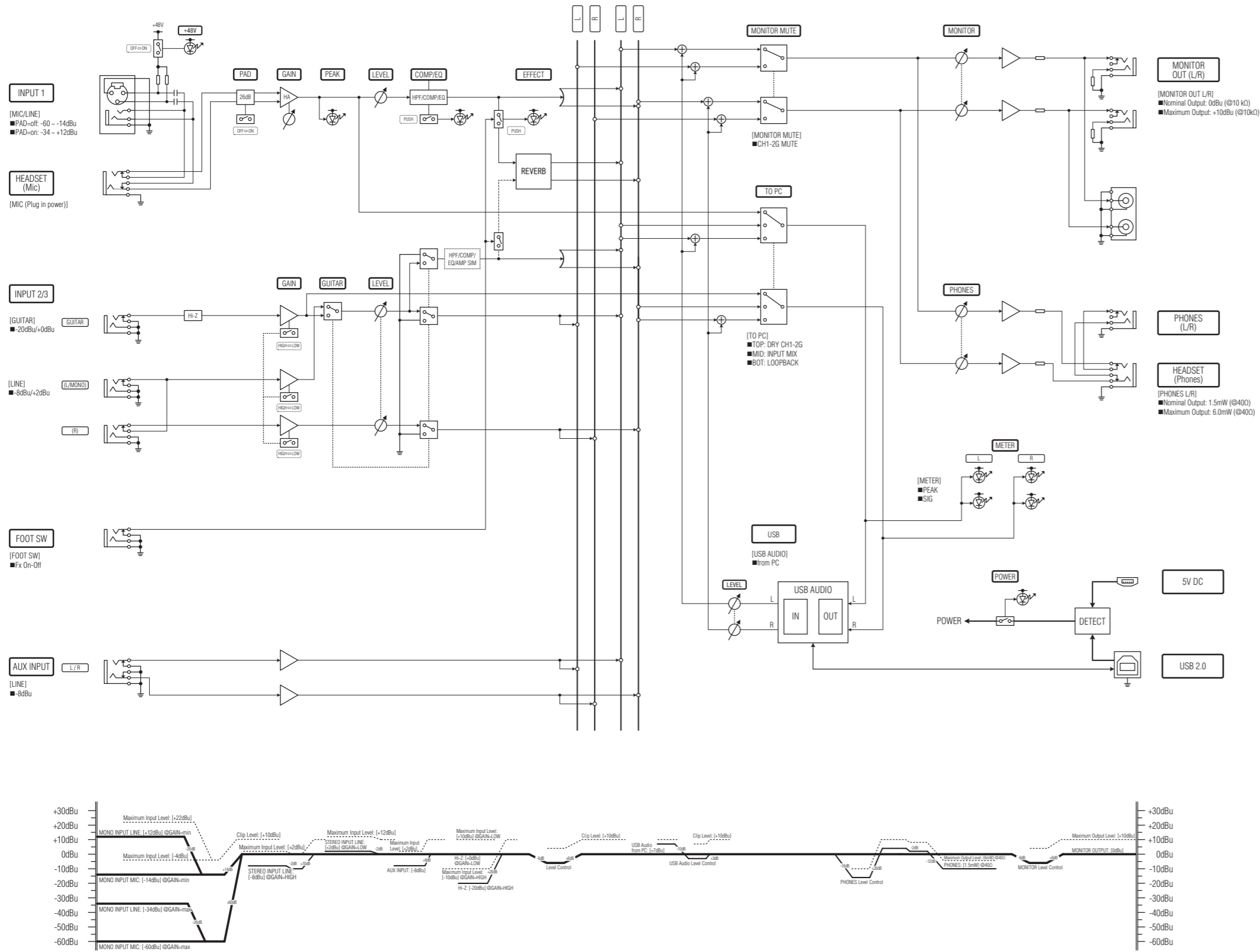

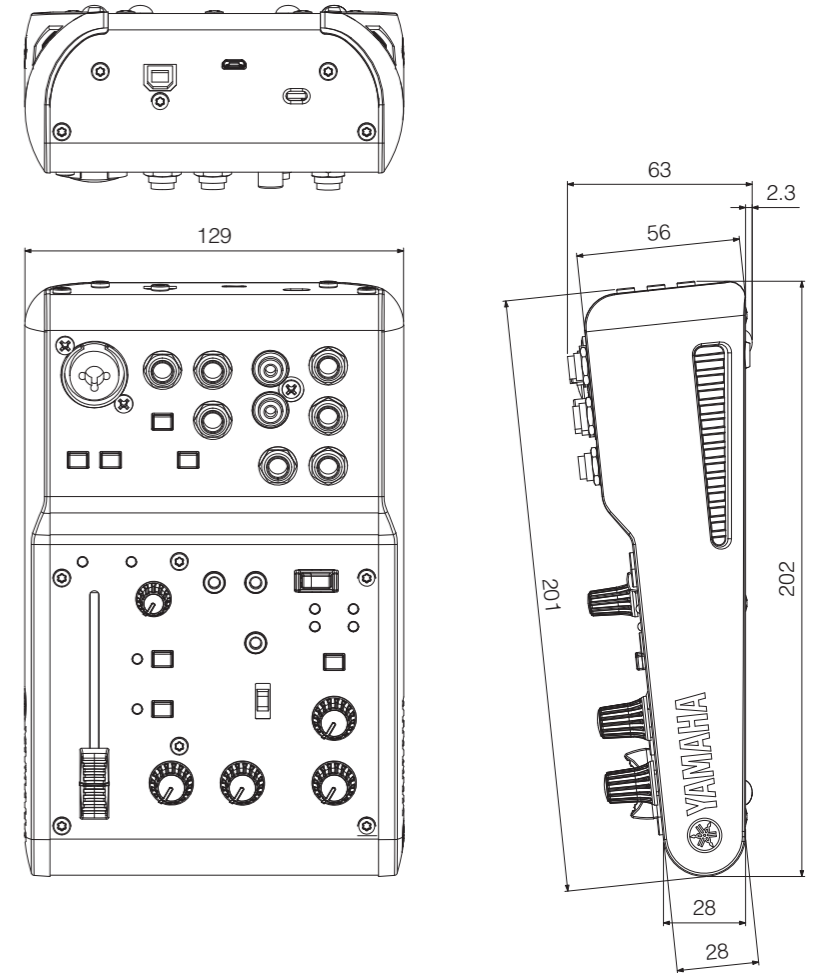

# Dimensions

Unit: mm

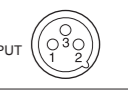
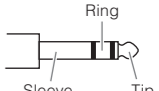
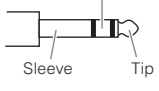
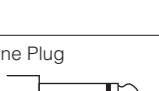

# Jack and Plug List

Jacks and Plugs	Polarities	Balanced/Unbalanced	Configurations
MIC/LINE	Pin 1: Ground Pin 2: Hot (+) Pin 3: Cold (-)	Balanced	XLR Jack 
MIC/LINE* MONITOR OUT*	Tip: Hot (+) Ring: Cold (-) Sleeve: Ground	Balanced	TRS Phone Plug 
HEADSET MIC	Tip: Signal Ring: - Sleeve: Ground	Unbalanced	
PHONES AUX	Tip: L Ring: R Sleeve: Ground	-	
LINE 2/3 GUITAR	Tip: Signal Sleeve: Ground	Unbalanced	TS Phone Plug 

\* These jacks also can be connected with TS phone plugs. If you use TS phone plugs, the connection will be unbalanced.