



ANALOG INPUT BOX **AI8**
MIC/LINE INPUT UNIT **AI8-ML8AB**
MIC/LINE INPUT UNIT **AI8-ML8F**
AD UNIT **AI8-AD8**

Owner's Manual

FCC INFORMATION (U.S.A.)

1. **IMPORTANT NOTICE: DO NOT MODIFY THIS UNIT!** This product, when installed as indicated in the instructions contained in this manual, meets FCC requirements. Modifications not expressly approved by Yamaha may void your authority, granted by the FCC, to use the product.
2. **IMPORTANT:** When connecting this product to accessories and/or another product use only high quality shielded cables. Cable/s supplied with this product **MUST** be used. Follow all installation instructions. Failure to follow instructions could void your FCC authorization to use this product in the USA.
3. **NOTE:** This product has been tested and found to comply with the requirements listed in FCC Regulations, Part 15 for Class "B" digital devices. Compliance with these requirements provides a reasonable level of assurance that your use of this product in a residential environment will not result in harmful interference with other electronic devices. This equipment generates/uses radio frequencies and, if not installed and used according to the instructions found in the users manual, may cause interference harmful to the operation of other electronic devices. Compliance with FCC regulations does not guarantee that interference will not occur in all installations. If this product is found to be the source of interference, which can be determined by turning the unit "OFF" and "ON", please try to eliminate the problem by using one of the following measures: Relocate either this product or the device that is being affected by the interference. Utilize power outlets that are on different branch (circuit breaker or fuse) circuits or install AC line filter/s. In the case of radio or TV interference, relocate/reorient the antenna. If the antenna lead-in is 300 ohm ribbon lead, change the lead-in to coaxial type cable. If these corrective measures do not produce satisfactory results, please contact the local retailer authorized to distribute this type of product. If you can not locate the appropriate retailer, please contact Yamaha Corporation of America, Electronic Service Division, 6600 Orangethorpe Ave, Buena Park, CA 90620

The above statements apply **ONLY** to those products distributed by Yamaha Corporation of America or its subsidiaries.

WARNING: THIS APPARATUS MUST BE EARTHED

IMPORTANT

THE WIRES IN THIS MAINS LEAD ARE COLOURED IN ACCORDANCE WITH THE FOLLOWING CODE:

GREEN-AND-YELLOW :	EARTH
BLUE :	NEUTRAL
BROWN :	LIVE

As the colours of the wires in the mains lead of this apparatus may not correspond with the coloured markings identifying the terminals in your plug, proceed as follows:

The wire which is coloured GREEN and YELLOW must be connected to the terminal in the plug which is marked by the letter E or by the safety earth symbol \perp or coloured GREEN and YELLOW.

The wire which is coloured BLUE must be connected to the terminal which is marked with the letter N or coloured BLACK.

The wire which is coloured BROWN must be connected to the terminal which is marked with the letter L or coloured RED.

* This applies only to products distributed by YAMAHA KEMBLE MUSIC (U.K.) LTD.

■ Precautions

- Do not place a container with liquid or small metal objects on top of this unit. Liquid or metal objects inside this unit are a fire and electrical shock hazard.
- Do not allow water to enter this unit or allow the unit to become wet. Fire or electrical shock may result.
- Connect this unit's power cord only to an AC outlet of the type stated in this Owner's Manual or as marked on the unit. Failure to do so is a fire and electrical shock hazard.
- Be sure to connect to an appropriate outlet with a protective grounding connection. Improper grounding can result in electrical shock.
- Do not scratch, bend, twist, pull, or heat the power cord. A damaged power cord is a fire and electrical shock hazard.
- Do not place heavy objects, including this unit, on top of the power cord. A damaged power cord is a fire and electrical shock hazard. In particular, be careful not to place heavy objects on a power cord covered by a carpet.
- If you notice any abnormality, such as smoke, odor, or noise, or if a foreign object or liquid gets inside the unit, turn it off immediately. Remove the power cord from the AC outlet. Consult your dealer for repair. Using the unit in this condition is a fire and electrical shock hazard.
- Should this unit/AC adapter/power supply be dropped or the cabinet be damaged, turn the power switch off, remove the power plug from the AC outlet, and contact your dealer. If you continue using the unit without heeding this instruction, fire or electrical shock may result.
- If the power cord is damaged (i.e., cut or a bare wire is exposed), ask your dealer for a replacement. Using the unit with a damaged power cord is a fire and electrical shock hazard.
- Do not remove the unit's cover. You could receive an electrical shock. If you think internal inspection, maintenance, or repair is necessary, contact your dealer.
- Do not modify the unit. Doing so is a fire and electrical shock hazard.
- When setting up the product, make sure that the AC outlet you are using is easily accessible. If some trouble or malfunction occurs, immediately turn off the power switch and disconnect the plug from the outlet. Even when the power switch is turned off, electricity is still flowing to the product at the minimum level. When you are not using the product for a long time, make sure to unplug the power cord from the wall AC outlet.
- When rack-mounting the unit, allow enough free space around the unit for normal ventilation. This should be: 10 cm at the sides, 15 cm behind, and 30 cm above.
- For normal ventilation during use, remove the rear of the rack or open a ventilation hole.
- If the airflow is not adequate, the unit will heat up inside and may cause a fire.
- This unit has ventilation holes at the top, bottom, and rear to prevent the internal temperature rising too high. Do not block them. Blocked ventilation holes are a fire hazard.
- Hold the power cord plug when disconnecting it from an AC outlet. Never pull the cord. A damaged power cord is a potential fire and electrical shock hazard.
- Do not touch the power plug with wet hands. Doing so is a potential electrical shock hazard.
- The digital circuits of this unit may induce a slight noise into nearby radios and TVs. If noise occurs, relocate the affected equipment.
- XLR-type connectors are wired as follows: pin 1: ground, pin 2: hot (+), and pin 3: cold (-).

Rack Mounting Caution

If the unit is rack mounted and transported regularly, for example, when on a tour, we recommend that the rear of the unit be supported by fitting a pair metal brackets, one each side. The following drawing provides the information necessary to make such brackets.

Note that only one bracket is shown here and the bracket for the other side must be bent in the opposite direction.

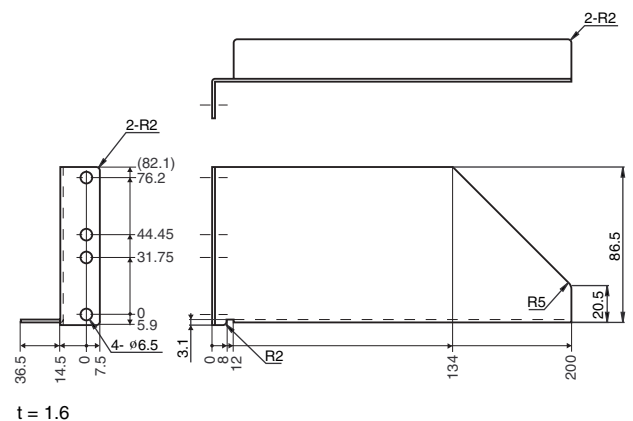

Thank you for choosing the AI8 analog input box, the AI8-ML8AB/AI8-ML8F mic line input unit, or the AI8-AD8 AD unit, specifically designed for the Yamaha PM1D digital audio mixing system. The AI8 inputs signals to the DSP unit DSP1D/DSP1D-EX engine (controlled via the CS1D control surface). Up to ten AI8s can be connected to each DSP1D/DSP1D-EX.

Be sure to ask an authorized Yamaha service engineer to install the card and set up the unit.
Never perform installation and setup by yourself.

Cards installable on the AI8 analog input box:

- LMY2-ML, LMY2-MLAB, LMY4-MLF : MIC/LINE input card
- LMY4-AD : AD card

Up to eight cards can be installed.

Unit models:

- **AI8-ML8AB** : AI8 analog input box that has eight LMY2-MLAB cards installed
- **AI8-ML8F** : AI8 analog input box that has eight LMY4-MLF cards installed
- **AI8-AD8** : AI8 analog input box that has eight LMY4-AD cards installed

■ Front panel

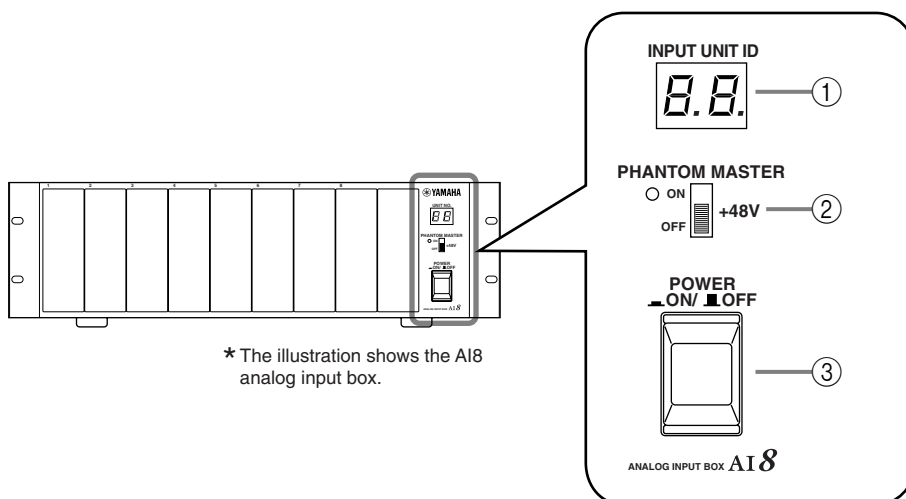

■ Rear panel

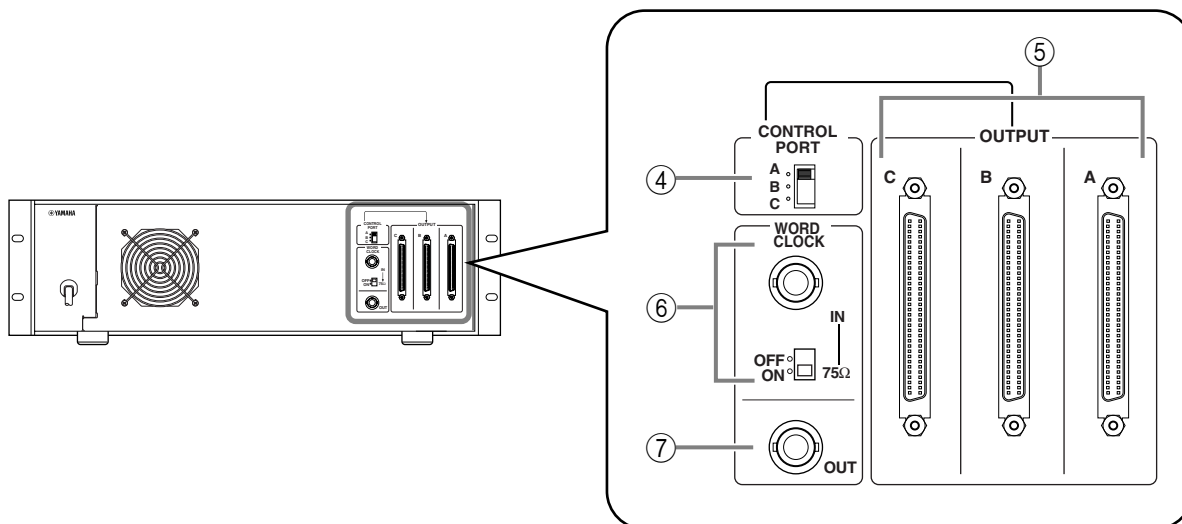

① INPUT UNIT ID indicator

This indicator displays the ID number of the INPUT connector of the DSP unit DSP1D/DSP1D-EX connected to the AI8. If an error occurs in the connection to the DSP1D, or if the unit does not lock to the word-clock signal, one of the following error indications appears.

Error message

E1: The AI8 is connected to the OUTPUT connector of the DSP1D/DSP1D-EX. Connect the AI8 to the INPUT connector.

E3: A cable is disconnected from the OUTPUT A, B, or C connector on the rear panel, or the connection is made incorrectly. If the connection is proper, replace the cable.

UL: The unit does not lock to the wordclock signal.

UC: The control signal is not being received correctly.

“.x.”:(two dots and the ID number of the OUTPUT connector on the DSP1D/DSP1D-EX)
Illuminating or flashing dots mean that the AI8 is connected in Mirror mode from the DSP1D/DSP1D-EX.

If “.x.” lights up continuously during Mirror mode operation, the CONTROL PORT switch (④) setting matches the setting controlled from the CS1D and the system is operating normally. If the control signal from the CS1D has changed the setting during Mirror mode operation and it does not match the CONTROL INPUT PORT switch (④) setting any more, this indicator changes in the following order.

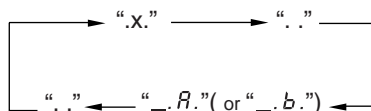

“._.A.” means that the control signal from the CS1D has changed the setting to “A.”

“._.b.” means that the control signal from the CS1D has changed the setting to “B.”

During this time period, you can connect or disconnect the cable from the unselected output connector.

If you set the CONTROL PORT switch so that it matches the setting made via the control signal from the CS1D, “.x.” lights up continuously.

② PHANTOM MASTER switch, indicator

This switch is used to turn the phantom power on and off to all the headphone amplifiers of the input connectors (for which the phantom power is switched on) on the AI8 that has the analog input card (LMY2-MLAB etc.) equipped with the headphone amplifier. When you turn on the switch, the indicator on the left of the switch lights up.

③ POWER ON/OFF

Use this switch to turn the power to the AI8 on and off. When the power is turned on, the INPUT UNIT ID indicator lights up.

④ CONTROL PORT switch

This switch enables you to select a port used to control the AI8 via the DSP unit DSP1D/DSP1D-EX. Select from OUTPUT A, B, and C to receive the control signal for switching between channels A and B on the analog input card (LMY2-MLAB etc.), or turning the phantom power on and off.

During Mirror mode operation, the control signal sent from the CS1D has priority, and the CONTROL PORT switch is disabled. In this case, the INPUT UNIT ID indicator shows the status. For more information, refer to ① INPUT UNIT ID indicator.

⑤ OUTPUT connectors A, B, C

These connectors are used to output multi-channel digital audio signals. The same signal is routed to all three connectors. Be sure to use the included genuine Yamaha half-pitch 68-pin cable for connection. Optional genuine Yamaha cables in a variety of lengths are also available.

⑥ WORD CLOCK IN jack, ON/OFF switch

The WORD CLOCK IN jack is used to provide the word clock to the AI8 from a connected external device or a clock generator. Use a BNC cable with an impedance of 75 Ω for connection.

The WORD CLOCK ON/OFF switch is used to terminate the word clock connection. Basically, if the AI8 is the last device of the word clock chain, or if nothing is connected to the WORD CLOCK IN/OUT jacks, set this switch to ON.

⑦ WORD CLOCK OUT jack

The WORD CLOCK OUT jack is used to provide word clock from the AI8 to the connected external device, such as a clock generator, digital MTR, and DAT recorder. Use a BNC cable with an impedance of 75 Ω for connection.

■ Specifications

Sampling frequency (external sync)	39.69 kHz – 50.88 kHz
Power supply	USA and Canada : 120 V, 60 Hz
	Others : 230 V, 50 Hz
Power consumption	120 W
Dimensions (W × H × D)	480 mm × 141.5 mm × 466.8 mm
Weight	15.4 kg
Operating temperature	10 – 35°C
Power cable length	2.1 m
Cooling fan speed	always fixed
Accessories	Connection cable (68-pin, D-sub, half-pitch) x 1, Length: 3m

Digital I/Os

I/O connectors	Level	Type
OUTPUT A, B, C	RS-422	D-sub, half-pitch, 68-pin connector (female)
WORD CLOCK IN	TTL/75 Ω (ON/OFF)	BNC Connector
WORD CLOCK OUT	TTL/75 Ω	BNC Connector

Slots

Card	Input
LMY2-ML	Channel 1A or 1B, 2A or 2B
LMY2-MLAB	Channel 1A or 1B, 2A or 2B
LMY4-MLF	Channel 1 – 4
LMY4-AD	Channel 1 – 4

■ Dimensions

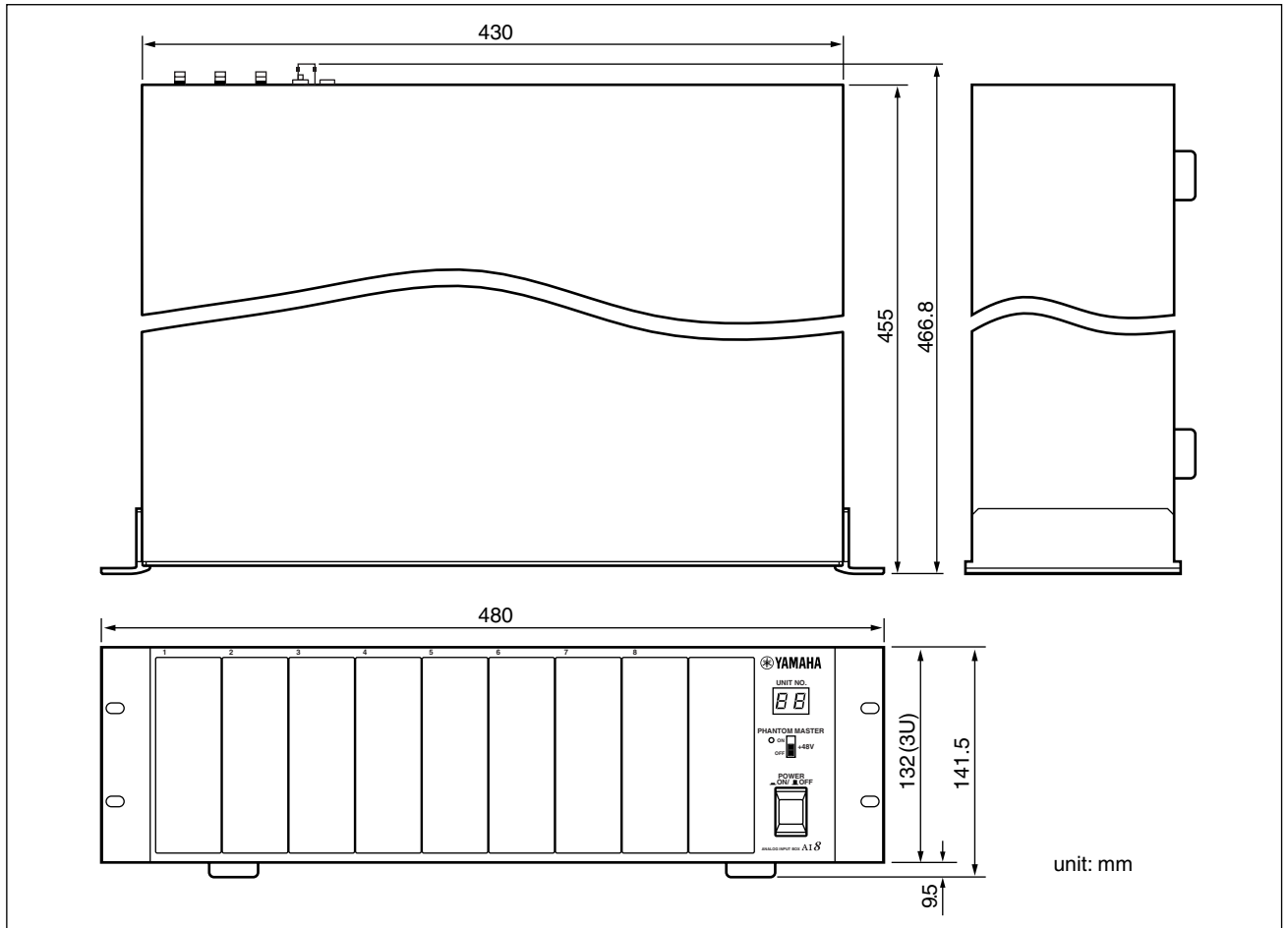

- Specifications and appearance are subject to change without notice for improvement.
- For European Model
Purchaser/User information specified in EN55103-1 and EN55103-2.
Inrush Current: 22A
Conformed Environment: E1, E2, E3 and E4.

For details of products, please contact your nearest Yamaha representative or the authorized distributor listed below.

Pour plus de détails sur les produits, veuillez-vous adresser à Yamaha ou au distributeur le plus proche de vous figurant dans la liste suivante.

Die Einzelheiten zu Produkten sind bei Ihrer unten aufgeführten Niederlassung und bei Yamaha Vertragshändlern in den jeweiligen Bestimmungsländern erhältlich.

Para detalles sobre productos, contacte su tienda Yamaha más cercana o el distribuidor autorizado que se lista debajo.

NORTH AMERICA

CANADA

Yamaha Canada Music Ltd.
135 Milner Avenue, Scarborough, Ontario,
M1S 3R1, Canada
Tel: 416-298-1311

U.S.A.

Yamaha Corporation of America
6600 Orangethorpe Ave., Buena Park, Calif. 90620,
U.S.A.
Tel: 714-522-9011

CENTRAL & SOUTH AMERICA

MEXICO

Yamaha de México S.A. de C.V.
Calz. Javier Rojo Gómez #1149,
Col. Guadalupe del Moral
C.P. 09300, México, D.F., México
Tel: 55-5804-0600

BRAZIL

Yamaha Musical do Brasil Ltda.
Rua Joaquim Floriano, 913 - 4º andar, Itaim Bibi,
CEP 04534-013 Sao Paulo, SP. BRAZIL
Tel: 011-3704-1377

ARGENTINA

Yamaha Music Latin America, S.A.
Sucursal de Argentina
Viamonte 1145 Piso2-B 1053,
Buenos Aires, Argentina
Tel: 1-4371-7021

PANAMA AND OTHER LATIN AMERICAN COUNTRIES/ CARIBBEAN COUNTRIES

Yamaha Music Latin America, S.A.
Torre Banco General, Piso 7, Urbanización Marbella,
Calle 47 y Aquilino de la Guardia,
Ciudad de Panamá, Panamá
Tel: +507-269-5311

EUROPE

THE UNITED KINGDOM

Yamaha-Kemble Music (U.K.) Ltd.
Sherbourne Drive, Tilbrook, Milton Keynes,
MK7 8BL, England
Tel: 01908-366700

GERMANY

Yamaha Music Central Europe GmbH
Siemensstraße 22-34, 25462 Rellingen, Germany
Tel: 04101-3030

SWITZERLAND/LIECHTENSTEIN

Yamaha Music Central Europe GmbH,
Branch Switzerland
Seefeldstrasse 94, 8008 Zürich, Switzerland
Tel: 01-383 3990

AUSTRIA

Yamaha Music Central Europe GmbH,
Branch Austria
Schleiergasse 20, A-1100 Wien, Austria
Tel: 01-60203900

CZECH REPUBLIC/SLOVAKIA/ HUNGARY/SLOVENIA

Yamaha Music Central Europe GmbH,
Branch Austria, CEE Department
Schleiergasse 20, A-1100 Wien, Austria
Tel: 01-602039025

POLAND

Yamaha Music Central Europe GmbH
Sp.z. o.o. Oddział w Polsce
ul. 17 Stycznia 56, PL-02-146 Warszawa, Poland
Tel: 022-868-07-57

THE NETHERLANDS/ BELGIUM/LUXEMBOURG

Yamaha Music Central Europe GmbH,
Branch Benelux
Clarissenhof 5-b, 4133 AB Vianen, The Netherlands
Tel: 0347-358 040

FRANCE

Yamaha Musique France
BP 70-77312 Marne-la-Vallée Cedex 2, France
Tel: 01-64-61-4000

ITALY

Yamaha Musica Italia S.P.A.
Combo Division
Viale Italia 88, 20020 Lainate (Milano), Italy
Tel: 02-935-771

SPAIN/PORTUGAL

Yamaha-Hazen Música, S.A.
Ctra. de la Coruna km. 17, 200, 28230
Las Rozas (Madrid), Spain
Tel: 91-639-8888

SWEDEN

Yamaha Scandinavia AB
J. A. Wettergrens Gata 1
Box 30053
S-400 43 Göteborg, Sweden
Tel: 031 89 34 00

DENMARK

YS Copenhagen Liaison Office
Generatorvej 6A
DK-2730 Herlev, Denmark
Tel: 44 92 49 00

NORWAY

Norsk filial av Yamaha Scandinavia AB
Grini Næringspark 1
N-1345 Østerås, Norway
Tel: 67 16 77 70

OTHER EUROPEAN COUNTRIES

Yamaha Music Central Europe GmbH
Siemensstraße 22-34, 25462 Rellingen, Germany
Tel: +49-4101-3030

AFRICA

Yamaha Corporation,
Asia-Pacific Music Marketing Group
Nakazawa-cho 10-1, Naka-ku, Hamamatsu,
Japan 430-8650
Tel: +81-53-460-2313

MIDDLE EAST

TURKEY/CYPRUS

Yamaha Music Central Europe GmbH
Siemensstraße 22-34, 25462 Rellingen, Germany
Tel: 04101-3030

OTHER COUNTRIES

Yamaha Music Gulf FZE
LOB 16-513, P.O.Box 17328, Jubel Ali,
Dubai, United Arab Emirates
Tel: +971-4-881-5868

ASIA

THE PEOPLE'S REPUBLIC OF CHINA

Yamaha Music & Electronics (China) Co.,Ltd.
25/F., United Plaza, 1468 Nanjing Road (West),
Jinan, Shanghai, China
Tel: 021-6247-2211

INDONESIA

PT. Yamaha Music Indonesia (Distributor)
PT. Nusantik
Gedung Yamaha Music Center, Jalan Jend. Gatot
Subroto Kav. 4, Jakarta 12930, Indonesia
Tel: 21-520-2577

KOREA

Yamaha Music Korea Ltd.
8F, 9F, Dongsung Bldg. 158-9 Samsung-Dong,
Kangnam-Gu, Seoul, Korea
Tel: 080-004-0022

MALAYSIA

Yamaha Music Malaysia, Sdn., Bhd.
Lot 8, Jalan Perbandaran, 47301 Kelana Jaya,
Petaling Jaya, Selangor, Malaysia
Tel: 3-78030900

SINGAPORE

Yamaha Music Asia Pte., Ltd.
#03-11 A-Z Building
140 Paya Lebar Road, Singapore 409015
Tel: 747-4374

TAIWAN

Yamaha KHS Music Co., Ltd.
3F, #6, Sec.2, Nan Jing E. Rd. Taipei.
Taiwan 104, R.O.C.
Tel: 02-2511-8688

THAILAND

Siam Music Yamaha Co., Ltd.
891/1 Siam Motors Building, 15-16 floor
Rama 1 road, Wangmai, Pathumwan
Bangkok 10330, Thailand
Tel: 02-215-2626

OTHER ASIAN COUNTRIES

Yamaha Corporation,
Asia-Pacific Music Marketing Group
Nakazawa-cho 10-1, Naka-ku, Hamamatsu,
Japan 430-8650
Tel: +81-53-460-2317

OCEANIA

AUSTRALIA

Yamaha Music Australia Pty. Ltd.
Level 1, 99 Queensbridge Street, Southbank,
Victoria 3006, Australia
Tel: 3-9693-5111

COUNTRIES AND TRUST TERRITORIES IN PACIFIC OCEAN

Yamaha Corporation,
Asia-Pacific Music Marketing Group
Nakazawa-cho 10-1, Naka-ku, Hamamatsu,
Japan 430-8650
Tel: +81-53-460-2313

HEAD OFFICE Yamaha Corporation, Pro Audio & Digital Musical Instrument Division
Nakazawa-cho 10-1, Naka-ku, Hamamatsu, Japan 430-8650
Tel: +81-53-460-2441