

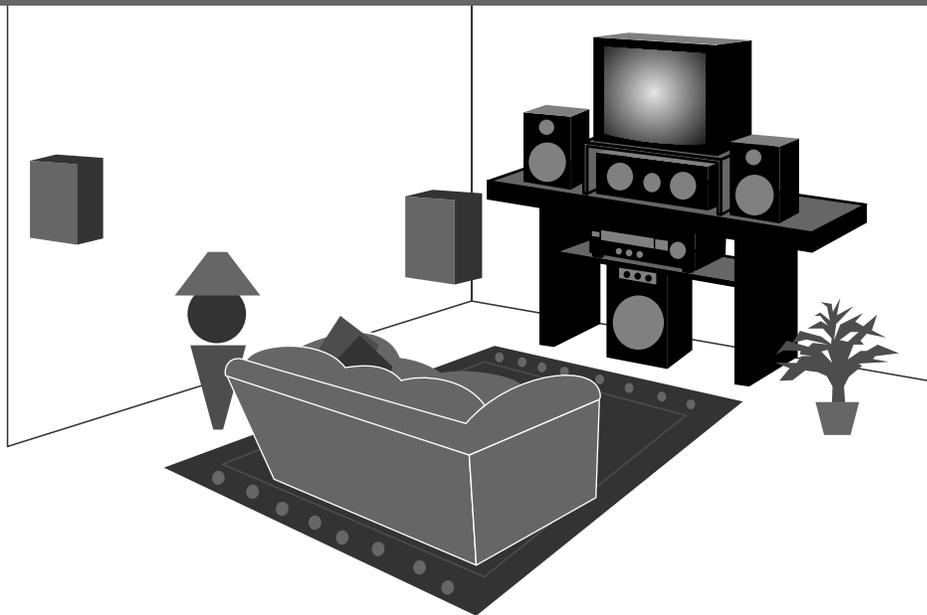

just add your TV and VCR

# home theater

SURROUND SOUND SYSTEM



**YHT-21**

**QUICK-CONNECT GUIDE**



## INTRODUCTION

Yamaha developed the YHT-21 A/V Home Theater package to turn your home into a theater. In addition to enhancing the sound of a video source, like your TV or VCR, the YHT-21 also superbly reproduces audio sources, such as a CD player or a cassette deck.

This Quick-Connect Guide will help you get started. Study the speaker system plan (below), and then use the interconnect diagrams (on the following pages) to connect the receiver and speakers to your system.

For the video portion, you will need a hi-fi stereo VCR or laser disc player and a television or monitor. Refer to the *Yamaha R-V703 Owner's Manual*, as well as those that came with your other components, for complete instructions and cautions. Be sure to turn off all power while making connections.

Save this Quick-Connect Guide for future reference.

*NOTE: Label the end of each speaker wire (i.e., left rear, right front, etc.) before connecting them to the A/V receiver. For wire runs over 30 feet, use larger 18- or 16-gauge speaker wire.*

## TOOLS AND PARTS

The YHT-21 Home Theater package consists of (1) R-V703 A/V receiver with (1) RAV141 remote control, (2) 2-way NS-A427 front-channel speakers and 16' of speaker wire, (1) NS-AP101 package containing (1) NS-AC2A 2-way center-channel speaker and (2) NS-A76A surround speakers with brackets and 72' of speaker wire, (1) YST-SW40 Powered Subwoofer, and related owner's manuals. You will also need:

- Wire strippers (optional)

- Velcro (for secure fastening of NS-AC2A on TV)
- Toggle bolts, molly anchor screws, or sheet metal screws (for securing NS-A76A speakers to walls)

*NOTE: If you are unsure of how to securely and safely fasten speakers to a wall, please contact a reliable source about the best type of hanger for your particular wall's construction. Secure installation is the purchaser's responsibility.*

## SPEAKER SYSTEM PLAN

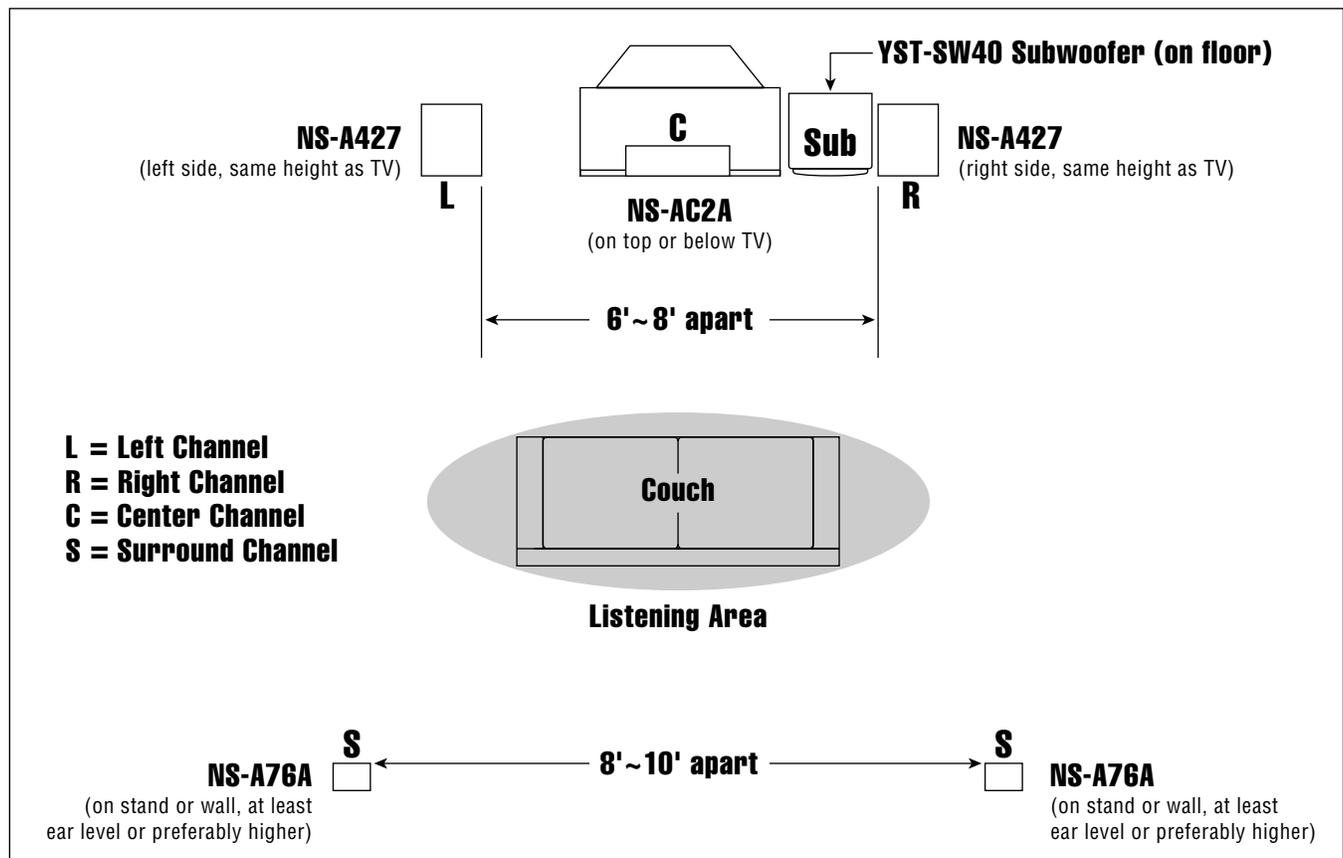

## CONNECTING AUDIO COMPONENTS

### Yamaha R-V703 Receiver (Rear Panel)

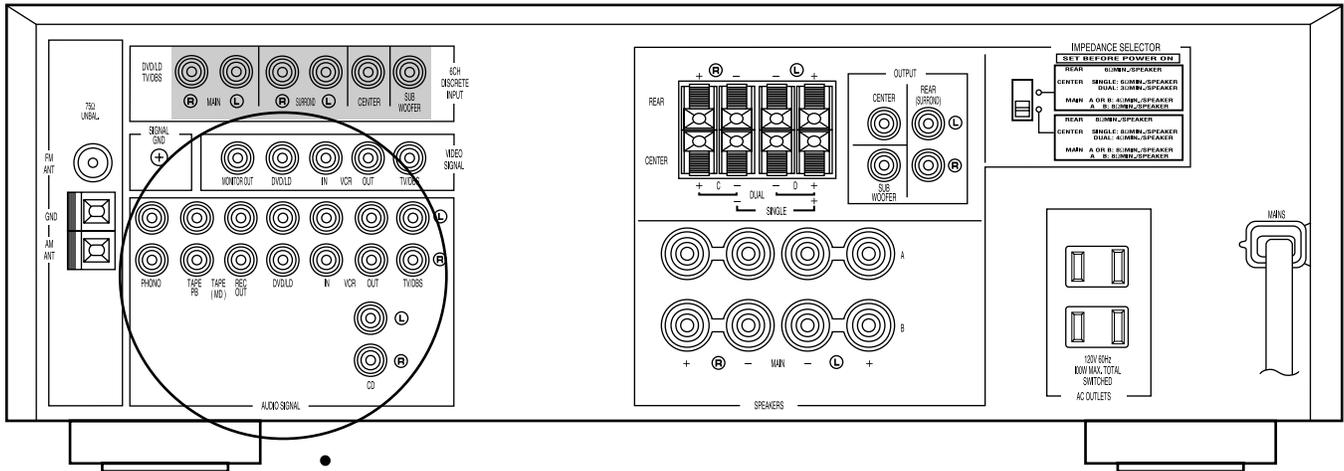

NOTE: For your convenience, the Yamaha R-V703 receiver is equipped with two switched AC outlets (100 W max.). If desired, use them to power on connected components (e.g., CD player or turntable) each time the receiver is turned on. However, do not use them for components equipped with clocks (e.g., VCR).

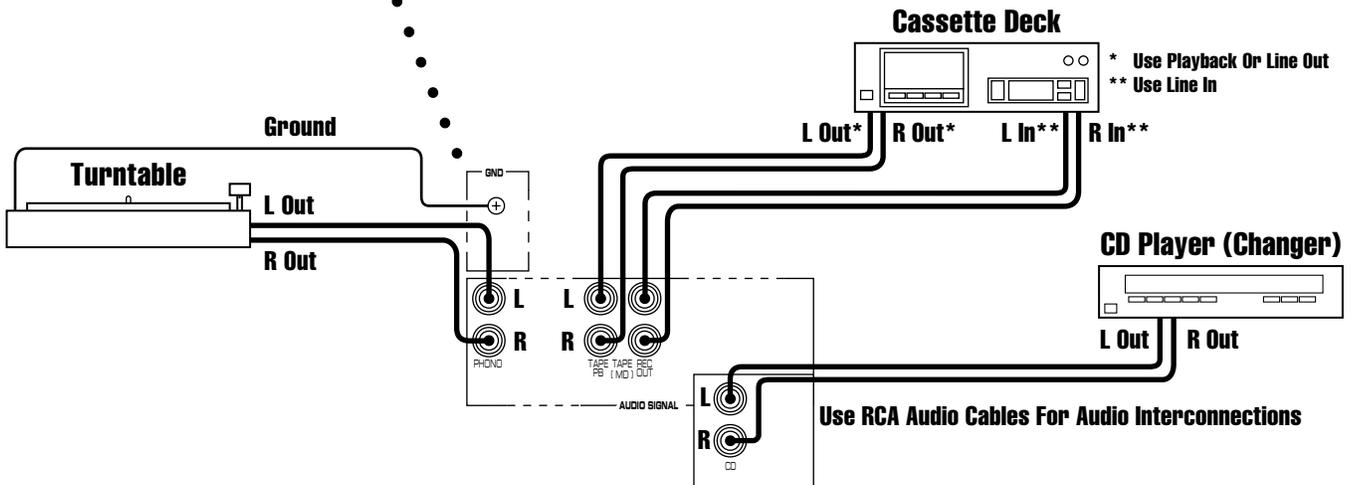

**RCA Cable Color Codes**  
 Yellow = Video  
 White = Left Audio  
 Red = Right Audio

## CONNECTING THE YHT-21 SPEAKERS

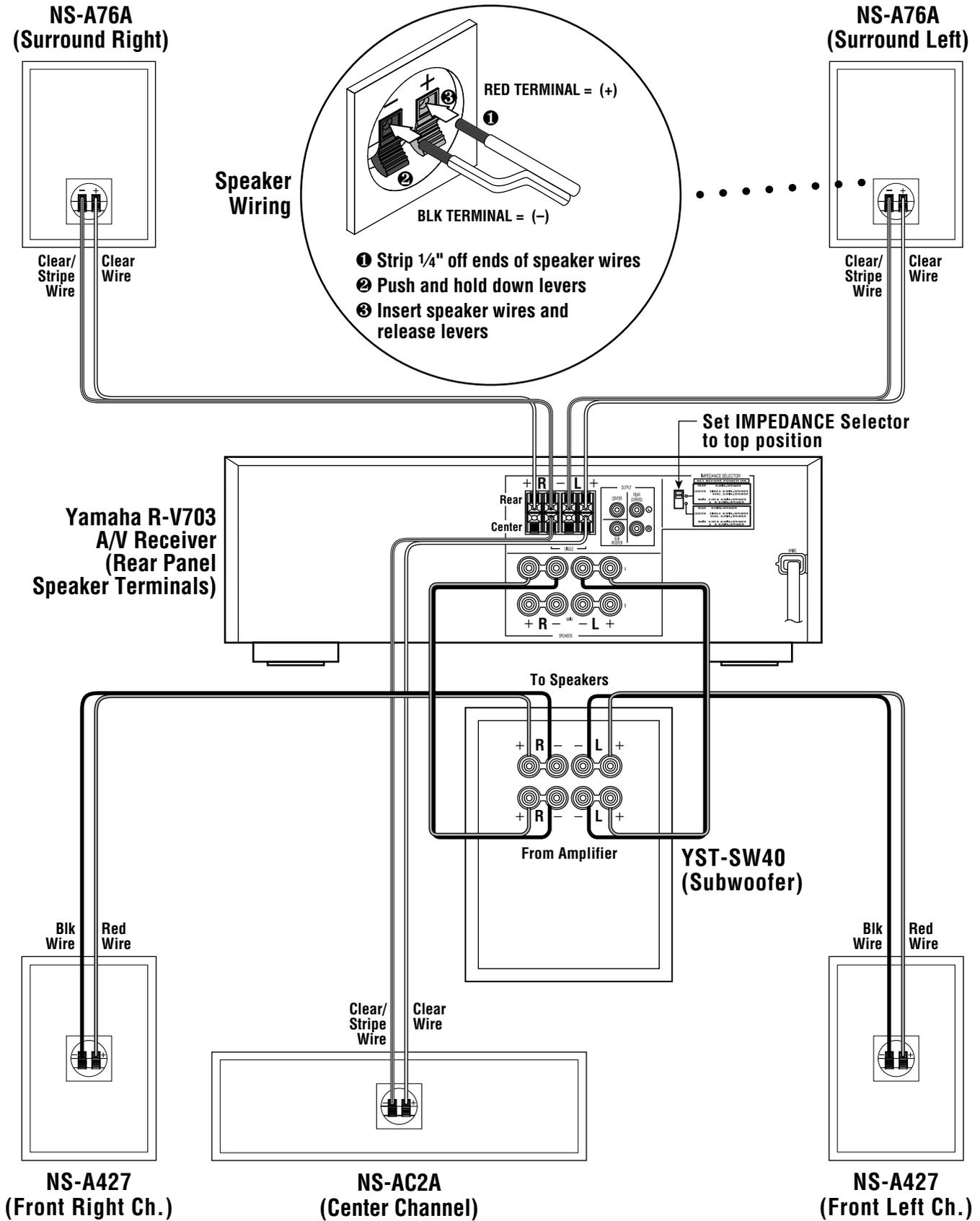

# YAMAHA YHT-21 QUICK-CONNECT GUIDE

## CONNECTING VIDEO CABLES FOR VIDEO COMPONENTS

### Yamaha R-V703 Receiver Rear Panel

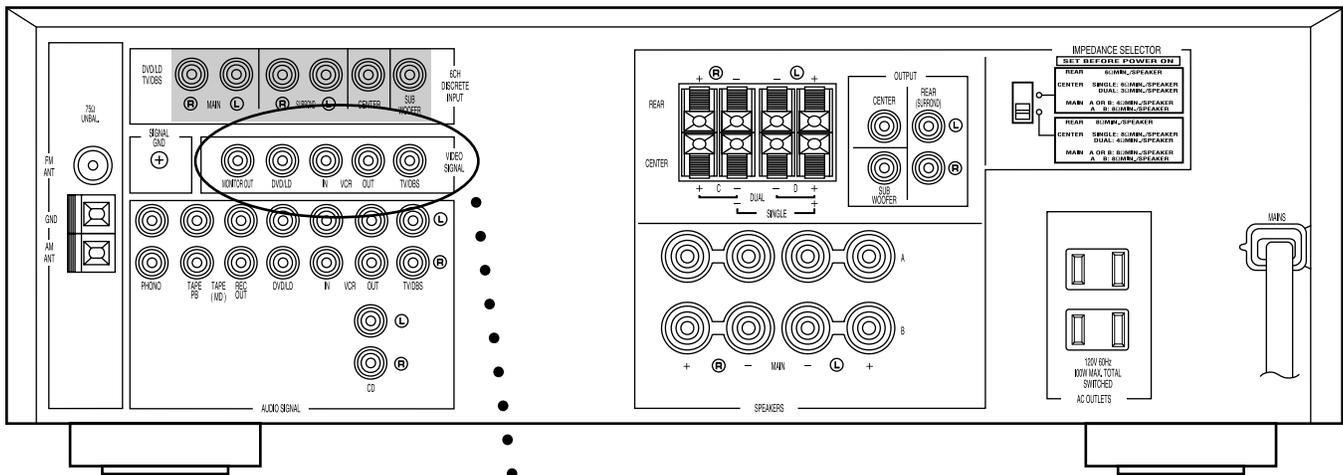

NOTE: When using a hi-fi stereo VCR, set the Tuner/Line switch (on the VCR) to Line position to record from another source connected to the Yamaha R-V703 receiver.

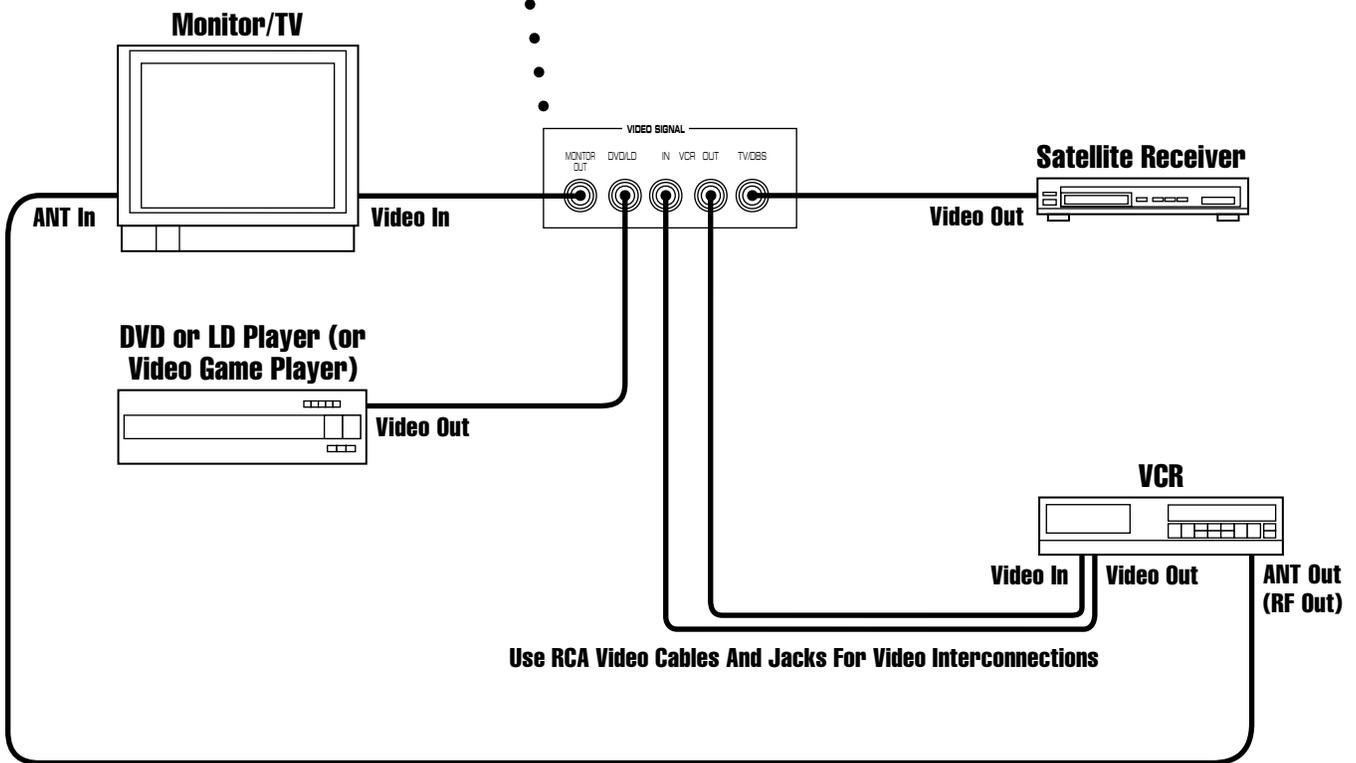

**RCA Cable Color Codes**  
 Yellow = Video  
 White = Left Audio  
 Red = Right Audio

## CONNECTING A 5.1-CHANNEL DECODER

If you own a 5.1-channel decoder (or a unit which incorporates a 5.1-channel decoder), you can connect its discrete outputs to the R-V703 as shown below.

- To hear playback of a stereo or mono audio source or one encoded with Dolby Pro Logic Surround\*, connect the unit (e.g., DVD player) to the DVD/LD (or TV/DBS) AUDIO SIGNAL input terminals.
- The discrete signals feeding to the R-V703 cannot be recorded by a tape deck, MD recorder, or VCR. To record programs from a source (e.g., laserdisc player), connect the source unit to the DVD/LD (or TV/DBS) AUDIO SIGNAL input terminals.
- If your audio system does not include a subwoofer (i.e., SUBWOOFER input terminals are not used), set signal routing on the 5.1-Channel Decoder so that the LFE channel feeds both LEFT and RIGHT MAIN output terminals. For details, refer to the owner's manual for your 5.1-Channel Decoder unit.

### Yamaha R-V703 Receiver Rear Panel

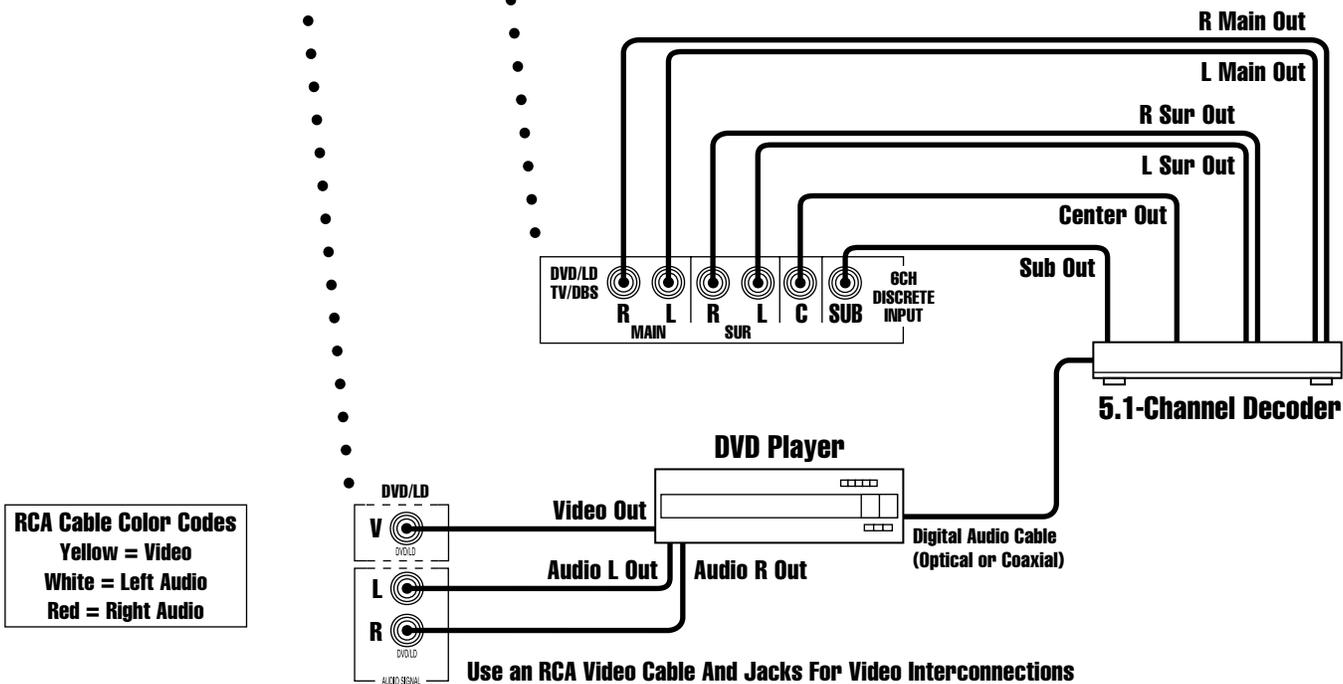
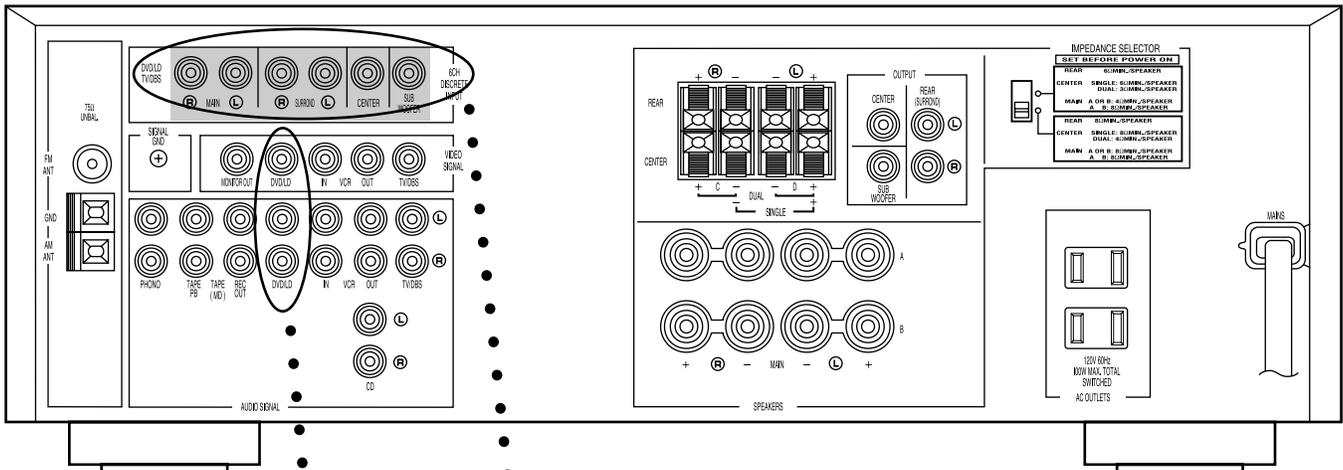

\*Dolby Pro Logic Surround is a trademark of Dolby Laboratories Licensing Corp.

# YAMAHA **YHT-21 QUICK-CONNECT GUIDE**

## CONNECTING A DVD PLAYER WITH BUILT-IN DOLBY DIGITAL (AC-3)\* DECODER

### Yamaha R-V703 Receiver Rear Panel

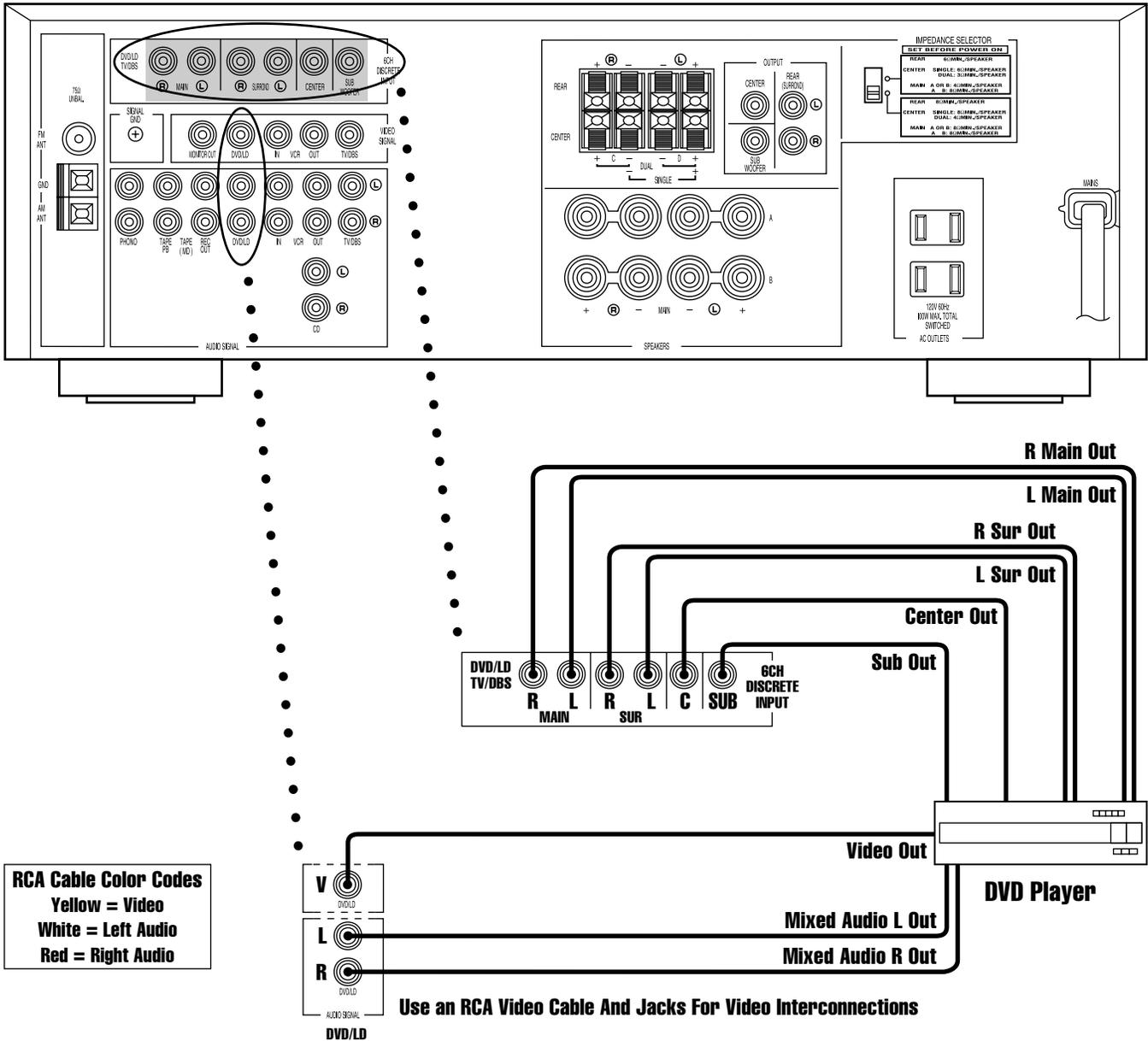

\*Dolby Digital and AC-3 are trademarks of Dolby Laboratories Licensing Corp.

## CONNECTING AUDIO CABLES FOR VIDEO COMPONENTS

### Yamaha R-V703 Receiver (Rear Panel)

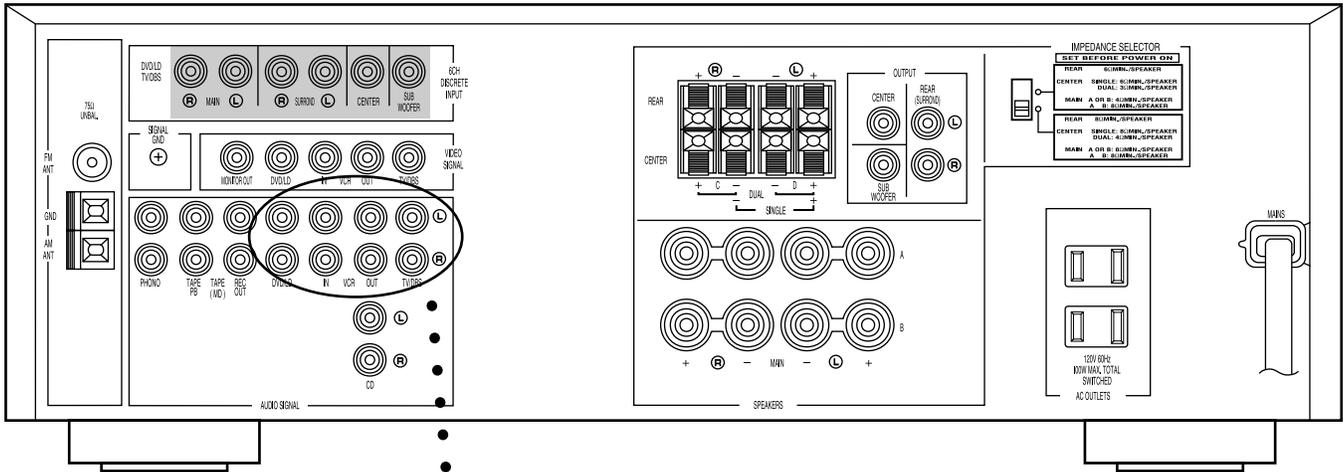

NOTE: When using a hi-fi stereo VCR, set the Tuner/Line switch (on the VCR) to Line position to record from another source connected to the Yamaha R-V703 receiver.

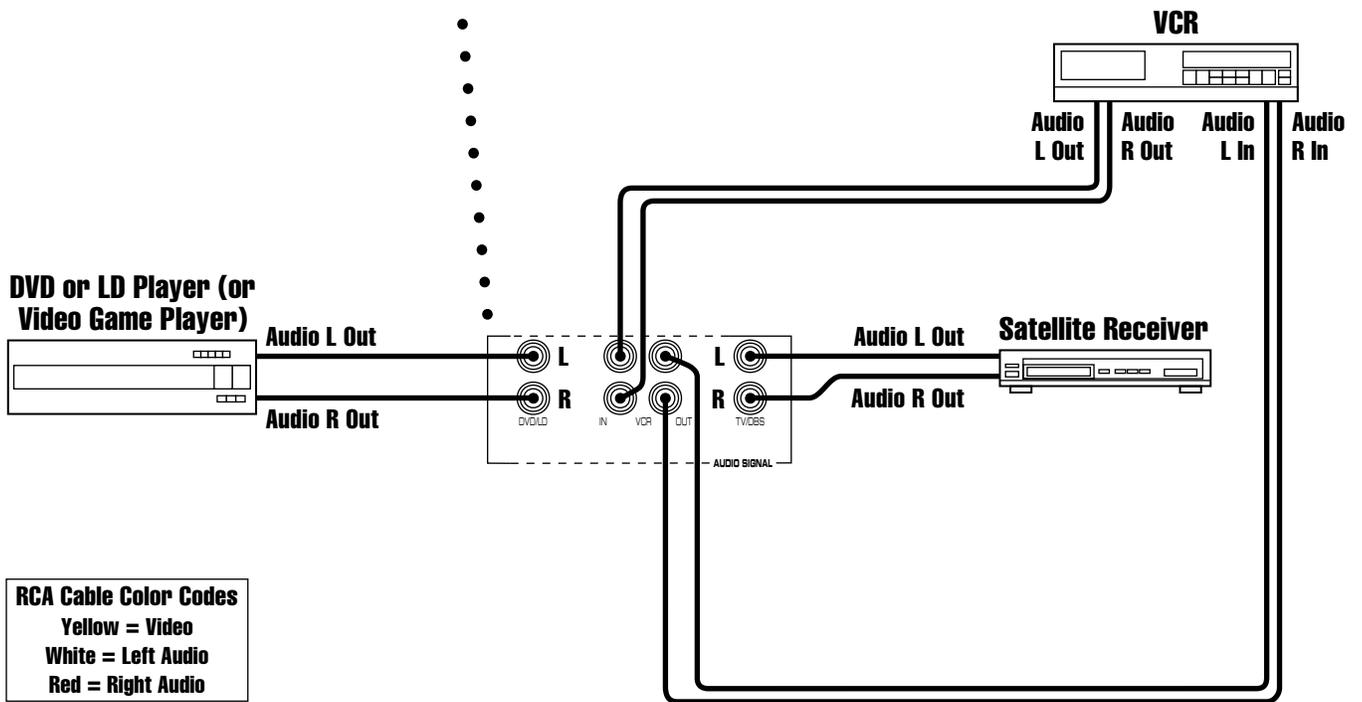

**RCA Cable Color Codes**  
 Yellow = Video  
 White = Left Audio  
 Red = Right Audio

Use RCA Audio Cables And Jacks For Audio Interconnections

# YAMAHA **YHT-21 QUICK-CONNECT GUIDE**

## CABLE HOOK-UP (BASIC AND PREMIUM CHANNELS)

### Yamaha R-V703 Receiver (Rear Panel)

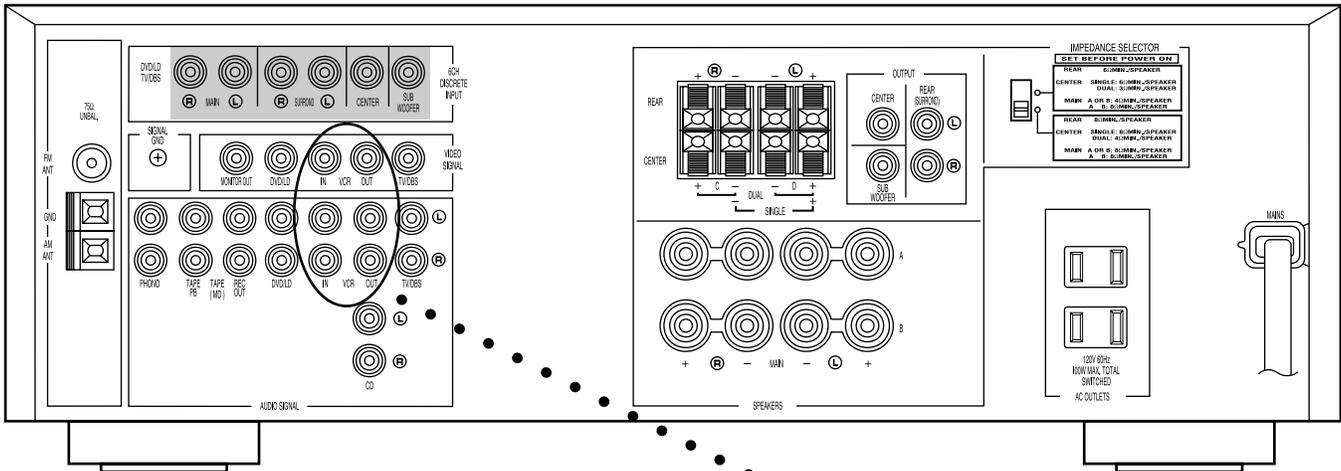

NOTE: When using a hi-fi stereo VCR, set the Tuner/Line switch (on the VCR) to Line position to record from another source connected to the Yamaha R-V703 receiver.

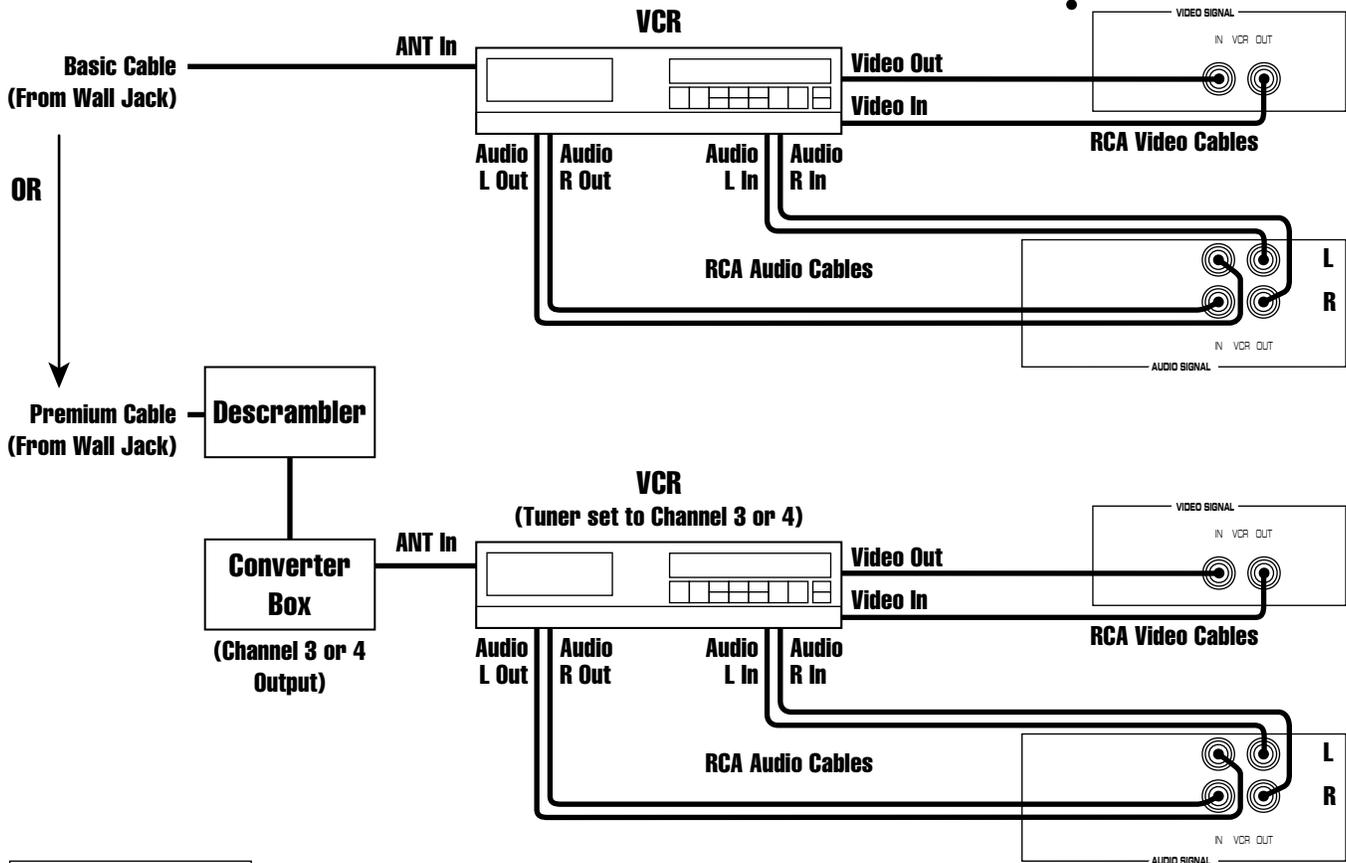

**RCA Cable Color Codes**  
 Yellow = Video  
 White = Left Audio  
 Red = Right Audio

## PROGRAMMING THE REMOTE CONTROL (RAV141)

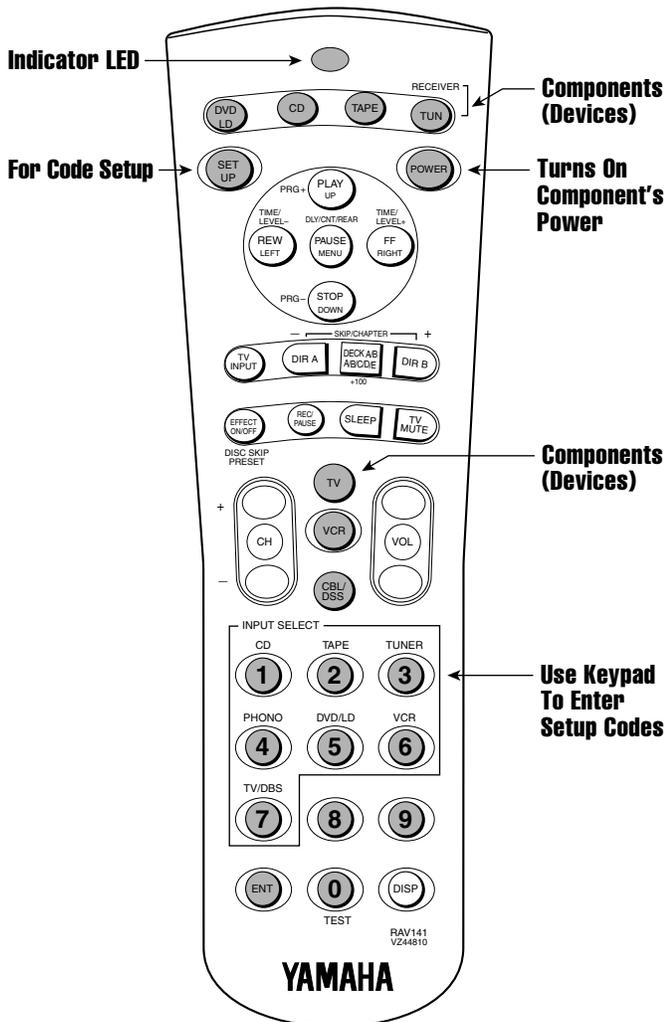

The YHT-21 Home Theater package includes the RAV141 Remote Control. It comes pre-programmed with factory codes to control your R-V703 receiver and most Yamaha audio components. To program other brands of components (i.e., TV, VCR, etc.) or if your Yamaha unit does not respond, you will need to program the remote control with the manufacturer's codes (listed on pages 33 through 36 of the *R-V703 Owner's Manual*).

*NOTE: The RAV141 is designed to control most major brands of audio and video components. For other units, use the original remote control supplied with the product.*

Perform the procedure for each component you own. At the end of step 5, the remote control's processor will automatically assign the selected component's control functions to its own buttons, ready for your use.

*NOTE: To clear the RAV141's memory and return it to the factory codes, press and hold **SETUP**; then enter 9 8 1.*

### POWER ON

1. Load the supplied batteries into the remote control.
2. Aim the unit at the receiver, press **RECEIVER/TUN**, and then press **POWER**.
3. The receiver should turn on.

### SETTING UP YOUR TV

1. Look up a setup code for your television set (on pages 35 and 36 of the *R-V703 Owner's Manual*).
2. Turn on the television set.
3. On the remote control, press **TV**; then press and hold **SETUP** until the indicator LED flashes twice.
4. Using the keypad, enter the three-digit number. The indicator LED will flash twice after your entry.
5. The TV's controls are now assigned to the remote control buttons (see *Quick Reference Card* for use). To test the code, press **TV** and then **POWER**. If the TV does not respond, try an alternate code.

### SETTING UP YOUR CABLE BOX (OR DSS)

1. Look up a setup code for your cable box or digital satellite system (see page 33 through 35 of the *R-V703 Owner's Manual*).
2. Turn on the cable box (or DSS).
3. On the remote control, press **CBL/DSS**; then press and hold **SETUP** until the indicator LED flashes twice.
4. Using the keypad, enter the three-digit number. The indicator LED will flash twice after your entry.
5. The unit's controls are now assigned to the remote control buttons (see *Quick Reference Card* for use). To test the code, press **CBL/DSS** and then **POWER**. If the unit does not respond, try an alternate code.

### SETTING UP YOUR VCR

1. Look up a setup code for your VCR (on page 36 of the *R-V703 Owner's Manual*).
2. Turn on the VCR.
3. On the remote control, press **VCR**; then press and hold **SETUP** until the indicator LED flashes twice.
4. Using the keypad, enter the three-digit number. The indicator LED will flash twice after your entry.
5. The VCR's controls are now assigned to the remote control buttons (see *Quick Reference Card* for use). To test the code, press **VCR** and then **POWER**. If the unit does not respond, try an alternate code.

*continued on the next page...*

## PROGRAMMING THE REMOTE CONTROL (CONT'D)

### SETTING UP YOUR DVD (OR LD) PLAYER

1. Look up a setup code for your DVD or LD player (on page 34 of the *R-V703 Owner's Manual*).
2. Turn on the DVD (or LD) player.
3. On the remote control, press DVD/LD; then press and hold SETUP until the indicator LED flashes twice.
4. Using the keypad, enter the three-digit number. The indicator LED will flash twice after your entry.
5. The unit's controls are now assigned to the remote control buttons (see *Quick Reference Card* for use). To test the code, press DVD/LD and then POWER. If the unit does not respond, try an alternate code.

### SETTING UP OTHER COMPONENTS (DEVICES)

1. Look up a setup code for your component (on pages 33 through 36 of the *R-V703 Owner's Manual*).
2. Turn on the component.
3. On the remote control, press the appropriate component button; then press and hold SETUP until the indicator LED flashes twice.
4. Using the keypad, enter the three-digit number. The indicator LED will flash twice after your entry.
5. The unit's controls are now assigned to the remote control buttons (see *Quick Reference Card* for use). To test the code, press the appropriate component button and then POWER. If the unit does not respond, try an alternate code.

## OPERATING THE REMOTE CONTROL (RAV141)

The RAV141 Remote Control will control up to seven different types of components (including the R-V703 receiver), each of which becomes active when you press a selection (e.g., TV, VCR, etc.). We can only briefly describe some functions here, and we encourage you use the *Quick Reference Card* and *R-V703 Owner's Manual* to gain additional experience with this powerful unit.

### PLAYING A VIDEOCASSETTE

1. Aim the remote control at the receiver, press the blue RECEIVER/TUN button, and then press POWER to turn it on. Press VCR (or 6) in the Input Select area.
2. Aim the remote control at the TV, press the blue TV button, and then press POWER to turn it on. Press TV INPUT to select the correct input.
3. Aim the remote control at the VCR, press the blue VCR button, and then press POWER to turn it on. Put a tape in the VCR, press PLAY.

*NOTE: At this point, the VCR controls are assigned to the remote control, since VCR was the last blue device button pressed. If you now press the VOLUME + (or -) buttons, the TV/VCR volume will be raised (or lowered). To adjust the receiver's volume, you must press the blue RECEIVER/TUN button to activate its functions.*

### PLAYING A DVD

1. Aim the remote control at the receiver, press the blue RECEIVER/TUN button, and then press POWER to turn it on. Press DVD/LD (or 5) in the Input Select area.
2. Press the power switch on the DVD player to turn the unit on.

*NOTE: If the DVD player is plugged into the switched AC outlet (on the back of the receiver) and its power switch was already engaged, the unit will come on each time the receiver is powered on.*

3. Load a DVD into the DVD player.
4. Aim the remote control at the DVD player, press the blue DVD button, and then press PLAY.

*NOTE: The DVD player's controls are now assigned to the remote control buttons, since DVD was the last blue device button pressed.*

5. Press the TV/DBS or DVD/LD button to switch the R-V703 inputs from the 2-channel stereo mode to the 6-channel discrete mode. This will accept signals from the unit connected to the 6CH DISCRETE INPUT terminals. Press the button again to return the R-V703 inputs to the 2-channel mode.

**YAMAHA®**

©1998 YAMAHA ELECTRONICS CORPORATION, USA  
6660 Orangethorpe Avenue, Buena Park, CA 90620  
PH: (714) 522-9105; FAX: (800) 782-8484  
<http://www.yamaha.com>